

Model 241CE II Hydrocarbon Dew Point Analyzer

Superior Benefits

- || Accurate and objective direct measurement of hydrocarbon dew point temperature at pipeline pressure or Cricondentherm
- || Proprietary three-stage sample filter provides superior protection
- || Designed for unattended operation with low maintenance
- || Electricity the only consumable
- || Compact design allows mounting in optional enclosures

The Need

Natural gas producers, distributors, and industrial consumers understand the importance of ensuring that natural gas meets various strict quality specifications which typically include a maximum hydrocarbon dew point temperature. Even relatively small quantities of liquids in natural gas transmission lines can damage sensitive metering equipment, plug lines, interfere with odorants, and most importantly, create unsafe conditions. Liquid drop out is not only an operational and safety concern, but may also result in errors in other critical measurement equipment. Hydrocarbon liquids in natural gas delivered to end-users can cause damage to gas turbines, upset plants using natural gas as chemical feedstock, increase emissions from burners, and compromise safety.

In many applications, automated on-line analyzers, such as the Western Research 241CE II Hydrocarbon Dew Point Analyzer, are replacing manual chilled mirror devices or calculation methods, which have traditionally been used to determine hydrocarbon dew point temperature. For over 15 years, AMETEK Western Research has provided an accurate and low-

maintenance analyzer for automated direct measurement of hydrocarbon dew point temperature in natural gas streams, using a patented chilled mirror design.

Direct Measurement

The Model 241CE II Analyzer uses a thermoelectric cooler to control the temperature of a two-surface mirror. During each measuring cycle, the microcontroller cools the mirror at a controlled rate until the optics have detected changes in light intensity that occur when liquids condense on the two surfaces of the mirror. Differences in surface tensions between liquid hydrocarbons and other condensables enable the analyzer to reject non-hydrocarbon dew points. This ability along with sensitive optics and a precisely controlled cooling rate provides improved accuracy and repeatability compared to a manual chilled mirror type device which depends on the training of the operator. The temperature of the mirror in the 241CE II is measured using a Platinum RTD which provides higher accuracy and long term stability compared to thermocouples.

The Model 241CE II is designed for unattended operation, in a complete package, without the need for

additional remote controllers, or costly sample systems. It carries CSA and ATEX certification for use in hazardous areas using an EEx d (flameproof) type enclosure. Sample gas flows through a measuring cell mounted on the outside of the flameproof electronics enclosure which simplifies sample system maintenance.

A fully integrated sample system package, including proprietary designed for natural gas samples, protects the analyzer from common natural gas contaminants (aerosols, particulates and liquid slugs) and ensures reliable, fast, and accurate means of detecting the hydrocarbon dew point temperature in natural gas applications.



Model 241CE II Hydrocarbon Dew Point Analyzer - European version shown on backpan. Analyzer must be installed in an environmentally controlled building or shelter.

Model 241CE II Hydrocarbon Dew Point Analyzer

Performance Specifications

Methodology: Chilled-mirror

Accuracy: Hydrocarbon dew point temperature $\pm 1^\circ\text{C}$ ($\pm 2^\circ\text{F}$)

Sensitivity: Temperature $\pm 0.1^\circ\text{C}$ ($\pm 0.2^\circ\text{F}$)

Sample Transport: 1/4 inch stainless steel instrument tubing recommended (heat tracing may be required)

Typical Flow: 1 to 5L/min. (2 to 10 scfh) depending on sample system configuration and pressure

Ambient Temperature: 10°C to 40°C (50° to 104°F)

Cooling Capability: Typically 60°C (108°F) below the temperature at the analyzer installation. The cooling capability of the analyzer is affected by the ambient temperature, sample gas composition and the pressure. (Consult your AMETEK representative for evaluation of your application.)

Highest Measurable Dewpoint:

Application dependent, typically 15°C (27°F) below the temperature at the analyzer installation

Maximum Working Pressure:

13.79 MPa (2000 psi)

Power: 120 VAC $\pm 10\%$, 60 Hz or 240 $\pm 10\%$ VAC, 50 Hz

Power Consumption: less than 275 W

Outputs: 4-to-20 mA (isolated, loop-power by customer or optional self-powered)

Physical Dimensions (H x W x D):

838 x 571.5 x 289 mm
(33 x 22.5 x 11.37 in.)

Weight: 60 kg (132 lbs.)

Approvals and Certifications:

Class I, Division 1, Groups C & D
ATEX II 2 G EExdIIBT4
Russian Ex Proof Certification;
1Exd IIB T3 X

CE Compliance: Complies with all relevant European Directives

Applications

- || Pipeline quality and custody transfer
- || Monitor inlet and outlet of storage facilities
- || Control of contractual blending operations
- || Monitor amount of superheat in gas turbine feed gas
- || Optimizing of switch times for pressure swing adsorption

Standard Features

Outputs

- || Hydrocarbon dew point temperature current output
- || Digital communications via Modbus RTU protocol

Sample System

- || Fully integrated sample system, including three-stage natural gas filter block and flow control
- || Optional regulator for measurement at Cricondentherm

User Interface

- || On-board microcontroller, display, and user interface
- || Optional remote start of measuring cycle available via external input

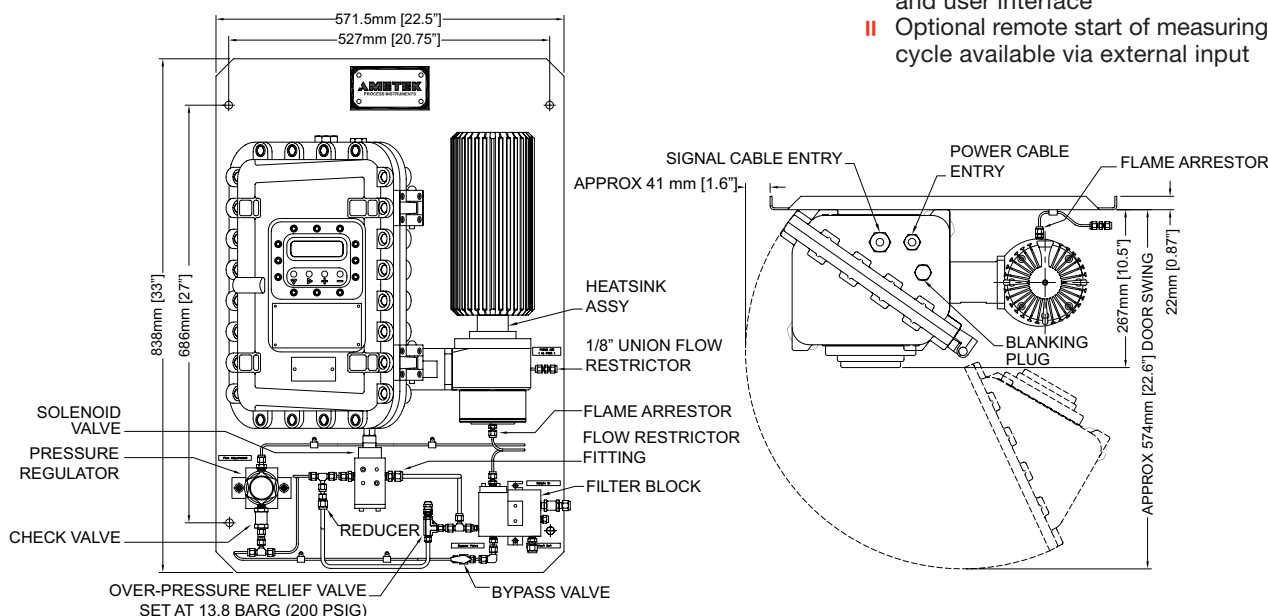

AMETEK[®]
PROCESS INSTRUMENTS

2876 Sunridge Way N.E., Calgary, AB T1Y 7H9
Ph. +1-403-235-8400, Fax +1-403-248-3550
www.ametekpi.com



© 2011, by AMETEK, Inc.
All rights reserved. Printed in the U.S.A.
F-0173 Rev 3 (0411)

One of a family of innovative process analyzer solutions from AMETEK Process Instruments.
Specifications subject to change without notice.

SALES AND MANUFACTURING:

USA - Delaware
455 Corporate Blvd., Newark DE 19702 • Tel: +1-302-456-4400, Fax: +1-302-456-4444

USA - Oklahoma
2001 N. Indianwood Ave., Broken Arrow OK 74012 • Tel: +1-918-250-7200, Fax: +1-918-459-0165

USA - Pennsylvania
150 Freepoint Road, Pittsburgh PA 15238 • Tel: +1-412-828-9040, Fax: +1-412-826-0399

WORLDWIDE SALES AND SERVICE LOCATIONS:

USA - Texas
Tel: +1-713-466-4900, Fax: +1-713-849-1924

CHINA
Beijing / Tel: 86 10 8526 2111, Fax: 86 10 8526 2141
Chengdu / Tel: 86 28 8675 8111, Fax: 86 28 8675 8141
Guangzhou / Tel: 86 20 8363 4768, Fax: 86 20 8363 3701
Shanghai / Tel: 86 21 5868 5111, Fax: 86 21 5866 0969

FRANCE
Tel: 33 1 30 68 89 20, Fax: 33 1 30 68 89 29

GERMANY
Tel: 49 21 59 91 36 0, Fax: 49 21 59 91 3639

INDIA
Tel: 91 80 6782 3200, Fax: 91 80 6782 3232

SINGAPORE
Tel: 65 6484 2388, Fax: 65 6481 6588

WESTERN RESEARCH[®]