

# Control of Fermentation Processes

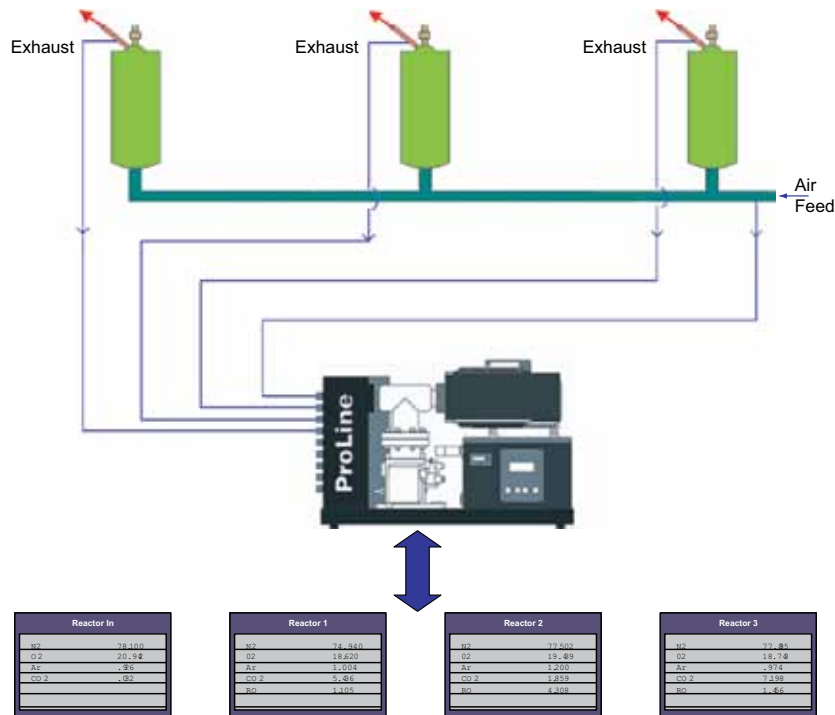

Reactor In	
O <sub>2</sub>	78.100
CO <sub>2</sub>	20.992
RQ	3.86
CO <sub>2</sub>	1.92

Reactor 1	
O <sub>2</sub>	74.940
CO <sub>2</sub>	18.220
RQ	1.000
CO <sub>2</sub>	5.46
RQ	1.000

Reactor 2	
O <sub>2</sub>	77.502
CO <sub>2</sub>	19.489
RQ	1.200
CO <sub>2</sub>	1.839
RQ	1.200

Reactor 3	
O <sub>2</sub>	77.85
CO <sub>2</sub>	18.74
RQ	2.19
CO <sub>2</sub>	7.398
RQ	1.66

## Process Overview

Fermentation is the process by which living organisms are cultured or grown to produce a specific product. The products can be as simple as baker's yeast and alcohols, or as complex as therapeutic proteins, antibiotics, enzymes, and genetically engineered materials. Regardless of the end product, fermentation reactions must be carefully monitored to gauge the health of the culture, and to determine when the culture can be harvested. Since these are living organisms, the levels of oxygen and carbon dioxide in the off-gases can be used to follow the progress of fermentation. The ratio of carbon dioxide to oxygen is called the respiratory quotient (RQ) and is the prime indicator of culture health. While these measurements can be made

by several techniques, the most accurate RQ determination requires complete knowledge of the flow of gases into and out of the reactor. By virtue of its ability to measure all of the gases entering and exiting the reactor, the ProLine process mass spectrometer provides a highly refined control signal to maximize culture health and productivity.

## Traditional Approach

**Dissolved O<sub>2</sub> and CO<sub>2</sub> Probes**  
 Fermentation reactors are typically equipped with insitu probes to measure dissolved O<sub>2</sub> and dissolved CO<sub>2</sub> in the broth. Both of these techniques are non-interactive, so that if one of the probes fails or falls out of calibration, the other probe does not reflect the failure. This would show as a shift in the balance of the respiratory quotient and might cause detrimental changes to

the process. Both types of dissolved probe typically have relatively long sampling times (on the order of minutes) and they also exhibit poor recovery response when dosed with higher levels of O<sub>2</sub> or CO<sub>2</sub>.

## FTIR

In some laboratories, Fourier Transform Infrared Spectroscopy (FTIR) systems measure CO<sub>2</sub> in the headspace and in conjunction with the dissolved CO<sub>2</sub> probes, they provide a more accurate, higher-confidence RQ value. However, the FTIR is limited by its relative lack of resolution and more complex calibration schemes. In general, the FTIR is used only for CO<sub>2</sub> headspace monitoring and therefore becomes a very expensive method to gather these numbers.

# Control of Fermentation Processes

## ProLine in Fermentation

The ProLine is a compact process mass spectrometer that can quantitatively measure all of the gases in the headspace above the culture simultaneously, with the sample point generally located at the exhaust port of the reactor. The inlet feed is also monitored. Sampling pressure can be either slightly above or slightly below atmospheric. Since the headspace is a high humidity environment, heated sample lines are used to prevent condensation before reaching the heated inlet manifold of the mass spectrometer.

### Ease of Maintenance and Calibration

The wide dynamic range of the ProLine allows gas species to be accurately measured from PPM to percent (%) levels using a single calibration gas. Other technologies such as gas chromatography (GC) and infrared spectroscopy (IR) require multi-point calibrations to cover the component ranges that are found in the analysis.

### Complete Reaction Information

Since the ProLine monitors the headspace of the reactor as well as the inlet gases, all of the expired components are measured and taken into account. Because of this, a complete mass balance measurement can be obtained and the necessary flow corrections made to ensure a true RQ value. This approach also provides rapid warning of a true RQ upset or any other abnormal conditions in the fermentation process.

### Speed of Analysis Allows Multiple Reactor Monitoring

The ProLine can report all of the gas components in as little as two seconds. Taking into account valve delays and settling times, the analyzer can deliver a set of data points approximately every 30 seconds. Since the ProLine can have up to 16 sampling valves, multiple reactors can be monitored with a single instrument. The typical fermentation analysis requires three calibration gases so that, even with the standard ProLine

8-valve system, five reactors can be controlled. Using one instrument also allows all of the data to be compared and catalogued more easily. Furthermore, GMP needs are met by logging all important events such as calibrations in a separate file. The weatherproof ProMaxion version offers up to 32 inlet ports for greater flexibility or for harsh environment locations. The ProMaxion is also available with hazardous area approval.



Figure 2. ProLine Process Mass Spectrometer for general purpose locations.

GAS	TYPICAL RANGE
N <sub>2</sub>	70 – 80%
O <sub>2</sub>	15 – 25%
Ar <sup>2</sup>	1 – 2%
CO <sub>2</sub>	5 – 10%
Ethanol	≤ 2000 PPM
Methanol	≤ 2000 PPM

Figure 1. Components and ranges for fermentation off-gas analysis.

### Summary of Benefits

- ▶ Increase product yield, decrease cycle time
- ▶ Optimize fermenter efficiency
- ▶ Simultaneously measure O<sub>2</sub>, CO<sub>2</sub>, N<sub>2</sub> and Ar
- ▶ Detect abnormal conditions
- ▶ Get fast response and high speed updates
- ▶ Monitor multiple reactors with one analyzer
- ▶ Use one system to replace many discrete analytical devices
- ▶ Eliminate RQ errors caused by probe failure
- ▶ Perform mass balance and RQ calculations

**AMETEK**  
PROCESS INSTRUMENTS

150 Freeport Road, Pittsburgh, PA 15238  
Ph. +1-412-828-9040, Fax +1-412-826-0399  
www.ametekpi.com



© 2011, by AMETEK, Inc.  
All rights reserved. Printed in the U.S.A.  
F-0333 Rev. 1 (0611)

One of a family of innovative process analyzer solutions from AMETEK Process Instruments.  
Specifications subject to change without notice.

#### SALES AND MANUFACTURING:

**USA - Delaware**  
455 Corporate Blvd., Newark DE 19702 • Tel: +1-302-456-4400, Fax: +1-302-456-4444

**USA - Oklahoma**  
2001 N. Indianwood Ave., Broken Arrow OK 74012 • Tel: +1-918-250-7200, Fax: +1-918-459-0165

**CANADA - Alberta**  
2876 Sunridge Way N.E., Calgary, AB T1Y 7H9 • Tel: +1-403-235-8400, Fax: +1-403-248-3550

#### WORLDWIDE SALES AND SERVICE LOCATIONS:

**USA - Texas**  
Tel: +1-713-466-4900, Fax: +1-713-849-1924

**CHINA**  
Beijing / Tel: 86 10 8526 2111, Fax: 86 10 8526 2141  
Chengdu / Tel: 86 28 8675 8111, Fax: 86 28 8675 8141  
Guangzhou / Tel: 86 20 8363 4768, Fax: 86 20 8363 3701  
Shanghai / Tel: 86 21 5868 5111, Fax: 86 21 5866 0969

**FRANCE**  
Tel: 33 1 30 68 89 20, Fax: 33 1 30 68 89 29

**GERMANY**  
Tel: 49 21 59 91 36 0, Fax: 49 21 59 91 3639

**INDIA**  
Tel: 91 80 6782 3200, Fax: 91 80 6782 3232

**SINGAPORE**  
Tel: 65 6484 2388, Fax: 65 6481 6588