

Installation and Operation of Densitometers

Introduction

One of the many parameters that must be accurately measured for product quality control, custody transfer, process control, or liquid interface detection purposes is liquid density. Often density measurement is combined with flow measurement to determine the mass flow rate of a liquid in a pipeline. What follows is a discussion of the principle of operation of vibrating tube densitometers, design suggestions for densitometer installation, and calibrating or “proving” the system.

Densitometer Types

There are different types of densitometers in use today. Some of the various operational principles for these devices are: vibration, buoyancy, nuclear, and acoustic. Each operation principle has advantages and disadvantages. The selection of the densitometer type usually depends on the application, performance requirements, and budget. We will restrict these discussions to vibrating tube densitometers.

Operating Principle

The simplest vibrating system consists of a spring and mass that are mechanically connected. If the mass is displaced and released, the system will vibrate at a known frequency defined by the equation,

$$\text{Frequency} = \frac{A}{2\delta} \sqrt{\frac{k}{m}}$$

where,

A = arbitrary constant, **k** = the spring constant, and **m** = the mass.

If the spring constant or the mass changes, the frequency of vibration or “natural frequency” will change.

This concept can be related to a vibrating tube densitometer. The spring constant (**k**) can be related to the stiffness of the tubing. The mass (**m**) can be related to the mass of the tubing plus the mass of the liquid in the tubing. As the mass (or density) of the fluid in the tubing varies, the natural frequency varies.

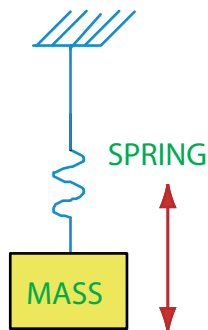

Vibrating Tube Densitometers

A vibrating tube densitometer is basically a spring-mass system in which the frequency of vibration of the tubing is measured and related to the fluid density. The tube assembly is supported at each end and is mechanically “excited” or displaced using electromechanical devices, so that the assembly will vibrate at the natural frequency.

As previously discussed, the frequency of vibration of the tube assembly will vary as the density of the fluid in the tubing changes. The tube assembly must have appropriate mechanical properties to resist corrosive attack from the fluid, be able to contain the pipeline pressure, and have proper vibration characteristics. The actual arrangement of the tubes will vary with manufacturer; parallel tubes, U-tube, and in-line tubing are the most common. The tube material is usually Ni-Span C, stainless steel or Hastelloy, although other materials have been used.

An efficient densitometer installation design will ensure that representative liquid pipeline sample is located inside the tube(s) at all times. The following equation is used to relate the frequency of vibration of the tubing to the actual fluid density.

$$\text{Uncorrected Density} = K_0 + K_1 t + K_2 t^2$$

where,

K_0 = calibration coefficient

K_1 = calibration coefficient

K_2 = calibration coefficient

t - 1/frequency = period of vibration

For increased accuracy, compensation for the effects of changing temperature and pressure on the tubing must be performed. To relate to the spring-mass example, changes in temperature and pressure cause small changes to the stiffness of the spring, causing variation in the frequency of vibration. The frequency shift caused by changing temperature and pressure can be described with second-order equations that are unique for each densitometer.

The coefficients used in these equations are supplied by the manufacturer when the densitometer is purchased or recertified. The coefficients do not change for a specific densitometer. During field calibration (or proving) of the densitometer, a density correction factor (DCF) is used to adjust the indicated or observed density of the densitometer to the actual density of the liquid. If the density correction factor varies beyond manufacturer recommendations, or the accuracy varies with the fluid density, the densitometer must be examined for possible defects and recertified.

Densitometer Signal Processing

The signal output from a vibrating densitometer is a “square wave” signal with a period or frequency equalling the vibration frequency of the tube assembly. From this signal, the frequency must be measured and the corrections for the effects of fluid temperature and pressure must be applied. The final determination is the density of the fluid. A flow computer is used to perform these calculations. In many cases, the flow computer is

also measuring the pipeline fluid flow rate using a turbine flow meter, an orifice meter, or other flow measurement device. Using the accumulated data, the fluid mass flow rate can be calculated. Depending on the application, the flow computer output values may be transferred using normal 4-20 mA signals, or conventional digital communication techniques such as RS-232C.

Densitometer Installation

The performance of a densitometer is highly dependent on the design of the installation. The following items must be considered during the design phase.

Flow Rate

Densitometers may be connected in parallel (bypass) or series (in-line) to a pipeline. When connected in series, the maximum flow rate through the densitometer must be considered. Densitometers are usually connected in parallel to the pipeline using a bypass loop if the pipeline flow rate is high. The flow rate in the bypass loop must be sufficient to provide a representative liquid sample from the pipeline, through the densitometer, and back to the pipeline. If this flow rate is too low, the time required to sense a change in pipeline density may be excessive and erratic readings can occur. The flow rate through the densitometer bypass loop is created using “scoops” in the main pipeline to induce flow. The differential pressure between the inlet and discharge scoops of the loop must be sufficient to ensure adequate flow. An orifice plate can be used to increase the differential pressure and the loop flow rate.

Liquid Phase

Unless stated otherwise, most densitometers are intended for use with single phase fluids. Unpredictable density measurements result if the liquid consists of varying mixtures of liquid and gas.

Distance from Pipeline and Related Flow

Measurement Devices

The distance between the densitometer, the pipeline, pycnometer connection, temperature and pressure measurements, and flow measurement devices must be minimized. By reducing these distances, the pressure drop through the bypass loop is minimized and the temperature of the entire system is more uniform.

Densitometer Insulation

The insulation of the densitometer and bypass loop is critical to provide a uniform temperature at the densitometer, at the pycnometer, and at the flow measurement site (turbine flow meter or orifice plate).

Orientation

The orientation of the densitometer is usually vertical or horizontal. The densitometer manufacturer has specific guidelines for performance in all orientations.

Pycnometer Connection

An insulated secondary flow loop must be provided for the pycnometer upstream of the densitometer in the primary

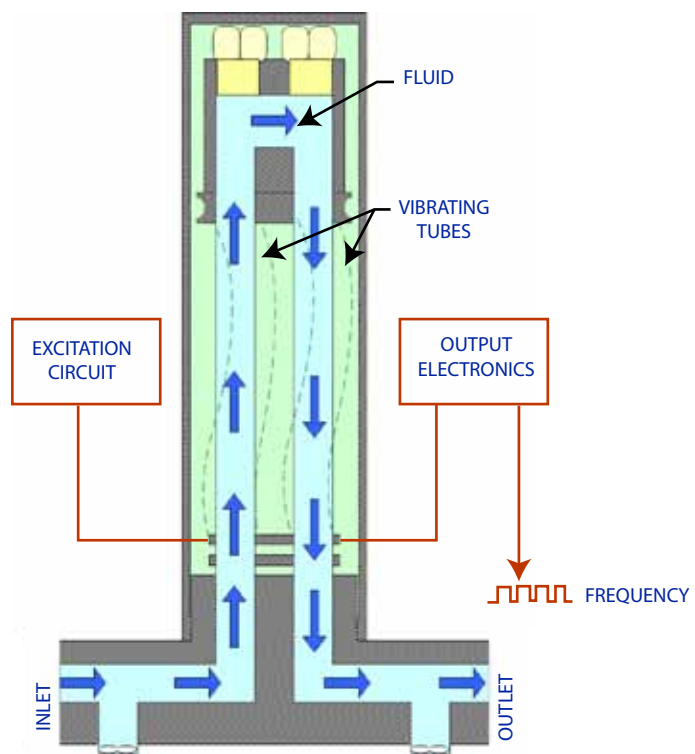

Figure 1: Typical densitometer

flow loop. This loop is used when the densitometer must be proved (calibrated).

Thermowells and Pressure Transducers

The final accuracy of the density and mass flow measurement is also dependent on the accuracy of the temperature and pressure measurements. The location of these measurements and the stability of the readings must be carefully considered.

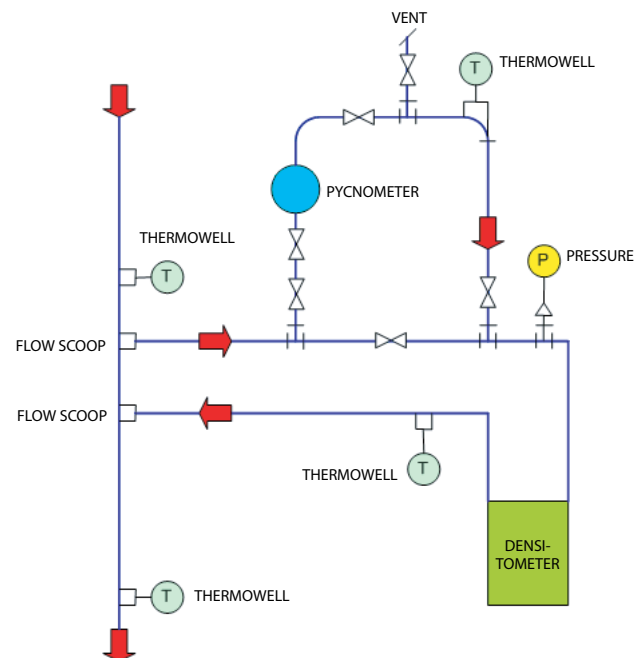

Figure 2: Typical flow diagram

Densitometer Proving

To verify the accuracy of the entire system, a densitometer must be proved or calibrated periodically.

The device used to perform this calibration is called a pycnometer. A pycnometer is a precision sphere of known mass and volume that is capable of withstanding pipeline pressures. The pycnometer is recommended for use by the American Petroleum Institute (API) for densitometer proving.

During the proving of the densitometer, the pycnometer is connected in series or parallel with the densitometer. Once temperature stability ($\pm 0.2^\circ\text{F}$) has been achieved at all locations in the flow loop, the pycnometer is removed and weighed. Once the tare mass, or empty mass of the pycnometer, has been subtracted, the liquid mass-per-unit-volume, or density, is calculated. This test is normally repeated until the readings are repeatable. Once this occurs, the density value is used to calculate the density correction factor, and is used to calculate the actual density in the flow computer or signal converter. The following equations are used.

$$\text{Density}_{\text{pyc}} = \frac{M_{\text{pyc}} - M_{\text{empty}}}{V_{\text{pyc}}}$$

$$\text{DCF} = \frac{\text{Density}_{\text{pyc}}}{\text{Density}_{\text{obs}}}$$

Where,

Density_{pyc} = Pycnometer density

M_{pyc} = Pycnometer mass (filled with fluid)

M_{empty} = Pycnometer empty mass (under vacuum)

V_{pyc} = Pycnometer volume (corrected for P and T)

Density_{obs} = Observed density

A certified, traceable weighing device must be used to determine the mass of the pycnometer. For optimum accuracy, verify the calibration of the weighing device using certified masses before proving a densitometer. Since the pycnometer empty mass is determined at standard temperature and pressure, and standard gravity (980 cm/sec^2), compensation for a difference in buoyancy at local ambient conditions and local gravity must be applied to weight values. See Reference 1 for a standard on density proving using a pycnometer.

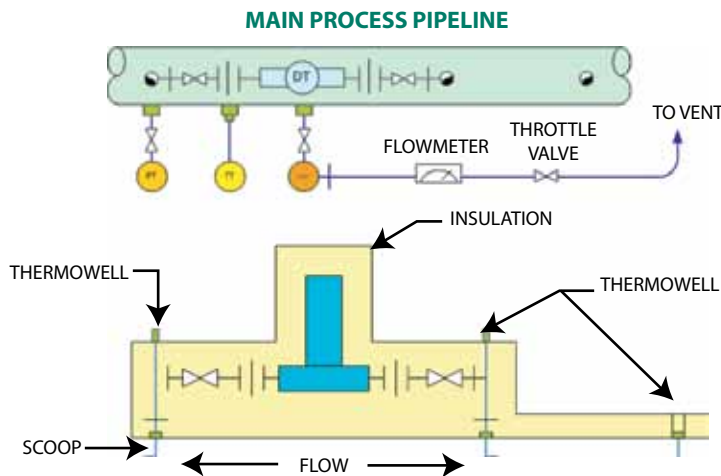

Figure 3.
Typical densitometer installation

DT = Densitometer
TT = Temperature Transducer
PT = Pressure Transducer
PVC = Pycnometer

1. API "Manual of Petroleum Measurement Standards," Chapter 14, Section 6.
2. Flow Measurements, D.W. Spitzer, Editor, I.S.A., 1991.

AMETEK®
PROCESS INSTRUMENTS

150 Freeport Road, Pittsburgh, PA 15238
Ph. +1-412-828-9040, Fax +1-412-826-0399
www.chandlerengineering.com



© 2011, by AMETEK, Inc.
All rights reserved. Printed in the U.S.A.
F-0344 Rev 1 (0111)

One of a family of innovative process analyzer solutions from AMETEK Process Instruments.
Specifications subject to change without notice.

SALES AND MANUFACTURING:

USA - Delaware
455 Corporate Blvd., Newark DE 19702 • Tel: +1-302-456-4400, Fax: +1-302-456-4444

USA - Oklahoma
2001 N. Indianwood Ave., Broken Arrow OK 74012 • Tel: +1-918-250-7200, Fax: +1-918-459-0165

CANADA - Alberta
2876 Sunridge Way N.E., Calgary, AB T1Y 7H9 • Tel: +1-403-235-8400, Fax: +1-403-248-3550

WORLDWIDE SALES AND SERVICE LOCATIONS:

USA - Texas
Tel: +1-713-466-4900, Fax: +1-713-849-1924

CHINA
Beijing / Tel: 86 10 8526 2111, Fax: 86 10 8526 2141
Chengdu / Tel: 86 28 8675 8111, Fax: 86 28 8675 8141
Guangzhou / Tel: 86 20 8363 4768, Fax: 86 20 8363 3701
Shanghai / Tel: 86 21 5868 5111, Fax: 86 21 5866 0969

FRANCE
Tel: 33 1 30 68 89 20, Fax: 33 1 30 68 89 29

GERMANY
Tel: 49 21 59 91 36 0, Fax: 49 21 59 91 3639

INDIA
Tel: 91 80 6782 3200, Fax: 91 80 6782 3232

SINGAPORE
Tel: 65 6484 2388, Fax: 65 6481 6588