

# More Powerful Data Can Improve Dryer Efficiency, Shorten Drying Cycles up to 50%

Real-time, data-rich measurement of solvent drying processes can improve process efficiency, ramp up process quality and satisfy PAT initiatives across a wide spectrum of drying operations.

By Tony Slapikas, AMETEK Process & Analytical Instruments

According to the U.S. Food and Drug Administration (FDA), "Within the PAT framework, a process endpoint need not be a fixed time, but can be the achievement of the desired material attributes."

The precision and detail with which you can measure the material's attributes, though, can make a real difference in how efficient your process operates.

For drying processes, common NIR and GC systems measure only final LOD (Loss on Drying), with little detail about internal processes.

By contrast, AMETEK's ProMaxion mass spectrometers give you not only all of the data you need to confirm dryness at the endpoint, but also the data you need to understand the entire drying cycle, in detail, so you can improve its efficiency and often shorten cycle times significantly.

The ProMaxion mass spectrometer lets you see solvent evaporation rate vs. dryer parameters essentially in real-time (delay = length of time required for the sample to traverse the distance from the dryer to the ProMaxion + instrument measurement time — typically one to two minutes, total).

Not only are the data available almost immediately, they are so detailed you can even identify dryer paddle rotations. And that means ProMaxion data can help you to determine precisely when all potential drying work has been accomplished at each process step, which helps identify ineffective drying steps and excessive durations. The data can even help you recognize the presence of feedstock variations and anomalies and flag deviations from production procedures in previous production steps.

## Detailed Data — Simple Operation

While the ProMaxion mass spectrometer provides unparalleled data detail and laboratory data quality, AMETEK's DryerPoint™ software makes operation so easy and automatic that the analyzer can be set up and run by the plant's production-line operators — no need for laboratory staff or specially trained instrument engineers. The DryerPoint software provides a simple, straightforward and intuitive user interface plus output that is easy to understand and use for process adjustment.

Because of the richness of its data, the ProMaxion is also an ideal tool to use to begin feeding data into a six-sigma (6σ) model and to aid quality assurance greenbelts and blackbelts in making process quality assessments and improvements.

## Analytical Flexibility, Simple Installation and Calibration

The ProMaxion mass spectrometer easily measures any combination of solvents, and you can change solvent analysis with each drying run. A multipoint, multipressure sample system with automatic purge allows one ProMaxion unit to accurately monitor up to seven dryers, even with different solvents in each dryer.

### Standards and Certifications

- ATEX T4 certified
- ISO certified
- NEC C1, D1 compliant
- FDA 21 CFR 11 compliant (software)
- IQ/OQ validation package available

Installation is also simple. One 6mm connection in the dryer vent header and a sample line run to the ProMaxion for each dryer is all that's required — no further dryer modifications or dryer wall penetrations are needed.

The ProMaxion unit can be air or water cooled, allowing operation at ambient temperatures from 12°C to 40°C, it works with all dryer types, and it offers a variety of communications options including Ethernet (standard), RS232, RS485, fiberoptic, wireless radio, Modbus and OPC. Inlet pressures can range from 207 kPa to 3 mm Hg absolute.

An onboard PC is optional, but the Windows®-based DryerPoint software can also be run on a remote PC. The instrument operates on standard 115/230 VAC, 50/60 Hz current, at a maximum power consumption of 1000 W.

The entire measuring and calibration process can be automated, and the ProMaxion output can be used to control all aspects of the drying cycle, without operator intervention.

Self-diagnostics and modular design ensure easy maintenance by your own plant maintenance staff. Modem support is also available for additional factory diagnosis and troubleshooting — no need for staff maintenance specialists or an expensive maintenance contract.

## Some Typical Examples

While the ProMaxion analyzer's results on specific pharmaceutical customers' production lines are generally protected by confidentiality agreements, the unit has helped identify:

1. A single-step process in which drying work stopped after less than half of the prescribed drying cycle.
2. A multi-step process in which no drying work was accomplished for an entire intermediate temperature cycle.
3. A process that continued to run for nearly a full day after the ProMaxion showed all drying work had ceased and the product was dry.

In each of these cases, the detailed process data allowed the company to adjust the drying process, with significant energy savings and cycle-time reductions.

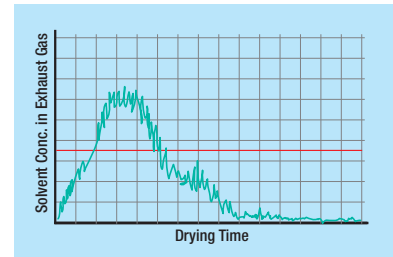

Here's what you can expect the ProMaxion output to show in a typical single-step process.

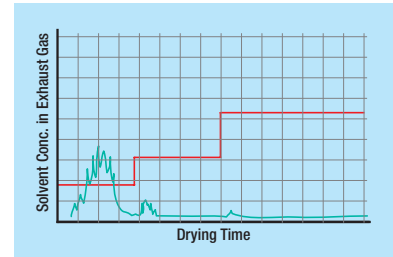

Here's what the ProMaxion output might look like in a typical three-step drying process.

To learn how a ProMaxion mass spectrometer might help you improve your drying operations, visit [www.ametekpi.com](http://www.ametekpi.com)



## ProMaxion™ Process Mass Spectrometer

### Front

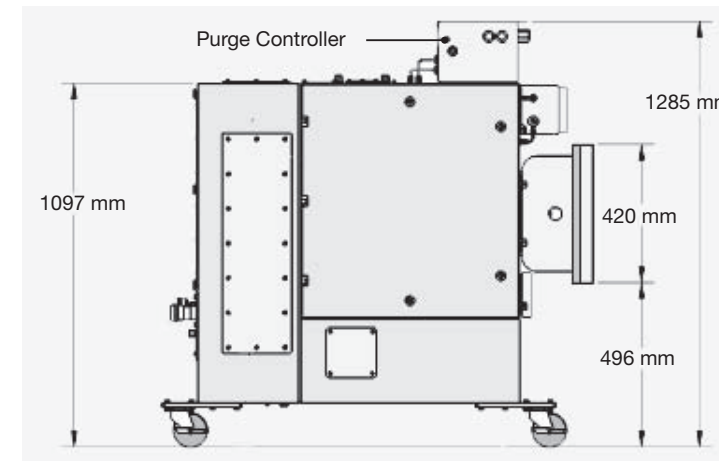

### Left Side

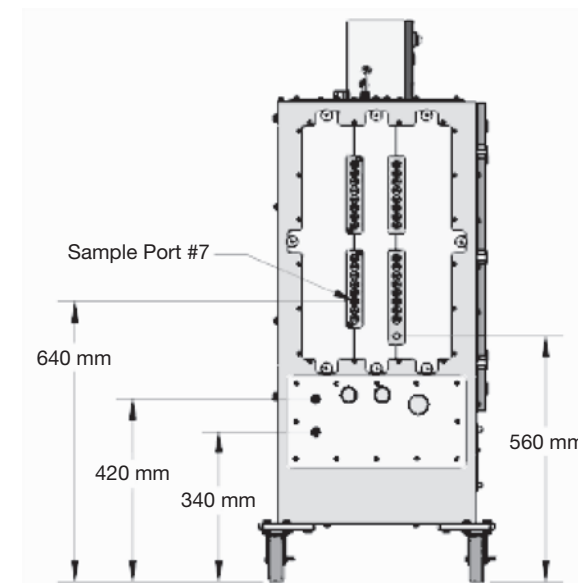

### Right Side

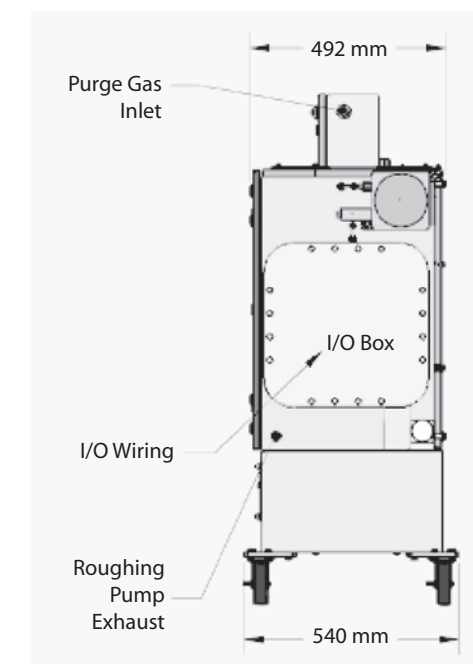

150 Freepoint Road, Pittsburgh, PA 15238  
Ph. +1-412-828-9040, Fax +1-412-826-0399  
[www.ametekpi.com](http://www.ametekpi.com)



© 2008, by AMETEK, Inc.  
All rights reserved. Printed in the U.S.A.  
080168NP (11/08)  
F-0111 Rev.1

One of a family of innovative process analyzer solutions from AMETEK Process Instruments.  
Specifications subject to change without notice.



# ProMaxion™ Mass Spectrometer

Quench your thirst for real-time solvent drying readouts.

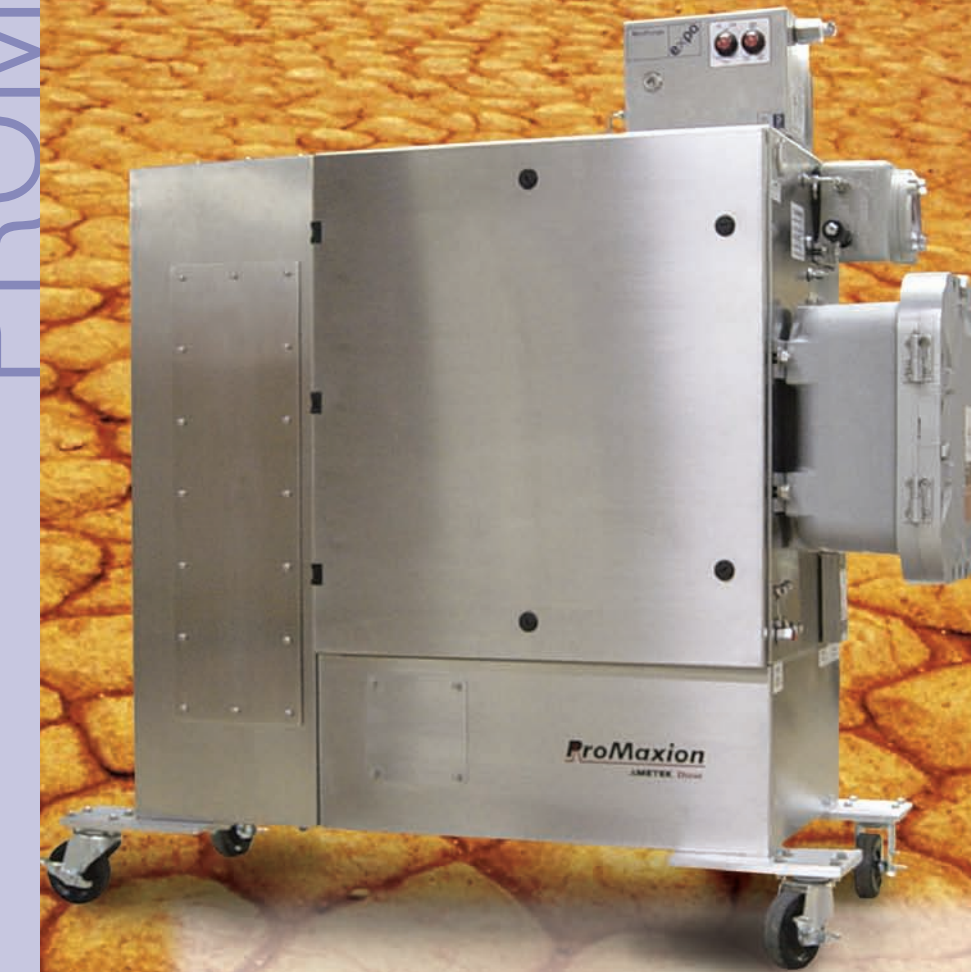

- Reduce drying time up to 50%
- Real-time solvent vapor analysis
- Easier set-up and operation than GC or NIR units
- IQ/OQ validation package available
- 21 CFR 11 compliant software

Stop wasting energy. Stop guessing when products are dry. And stop interrupting the process to find out. Only AMETEK's ProMaxion mass spectrometer gives you non-invasive, real-time analysis. You get continuous readouts instead of waiting hours or days. With ProMaxion's intuitive DryerPoint™ software, operators will be able to set up and use it without special training. And, by saving a third or more in drying time, for every three dryers you have it's like getting a fourth dryer free!

ProMaxion is also certified to ATEX T4 standards, and can help you achieve Six Sigma quality-compliant process operations. So *quench your thirst* for accurate solvent drying information. Learn more in the ProMaxion White Paper (in this brochure), or visit our Website [www.ametekpi.com](http://www.ametekpi.com)

[www.ametekpi.com](http://www.ametekpi.com)

# ProMaxion™ Process Mass Spectrometer

## Online Gas Analysis for Weatherproof or Hazardous Area Locations

AMETEK's ProMaxion™ Process Mass Spectrometer offers real-time gas analysis in a reliable easy-to-use package for a wide range of industrial applications. With more than 20 years' experience in mass spectrometer design and manufacture, and over six thousand quadrupole analyzers operating reliably worldwide, AMETEK alone has the credentials to bring you the ProMaxion—cost-effective, high-performance analysis for your process.



ATEX-version ProMaxion for hazardous location applications

### MULTICOMPONENT ANALYSIS

Real-time process monitoring of multiple components is straightforward with ProMaxion's powerful, easy-to-use Process 2000 Software. Complex overlapping spectra are handled automatically, with data output directly in concentration units. Different calibration and analysis methods can be assigned to each sample port.

### REPLACES PROCESS GAS CHROMATOGRAPHS

Mass spectrometry is a very rapid analytical method allowing analysis of multiple sample streams in seconds and can directly replace gas chromatographs and other discrete analytical devices. This field-proven system, combined with AMETEK's more than 30 years' experience in the process analyzer business, means you can depend on ProMaxion for your critical process analysis and control applications.

### EASY TO USE, EASY TO MAINTAIN

The software provides easy set-up and operation and includes advanced alarm and automation capabilities. Autocalibration maintains the performance and accuracy of the system for quantitative analysis. The on-board computer enables auto-start to prevent loss of data or interruption of your process during power failure. Self-diagnostics and modular design

ensure ease of maintenance by your own personnel on site, with remote support available for additional factory diagnosis and troubleshooting. There is no need for the expensive service contract typical of most process mass spectrometers.

### CUSTOM SAMPLE HANDLING

The ProMaxion can be custom-designed to monitor just about any type of gas stream, depending on sample pressures, hazardous area requirements, particulate levels and number of sample points. Automated sample switching allows unattended analysis of process and calibration gases. The multiport gas sample inlet system consists of multiple valves and a capillary restriction in an enclosure heated to prevent condensation. A membrane inlet system is incorporated for ambient air applications.

150 Freeport Road, Pittsburgh, PA 15238  
Ph. +1-412-828-9040, Fax +1-412-826-0399  
[www.ametekpi.com](http://www.ametekpi.com)

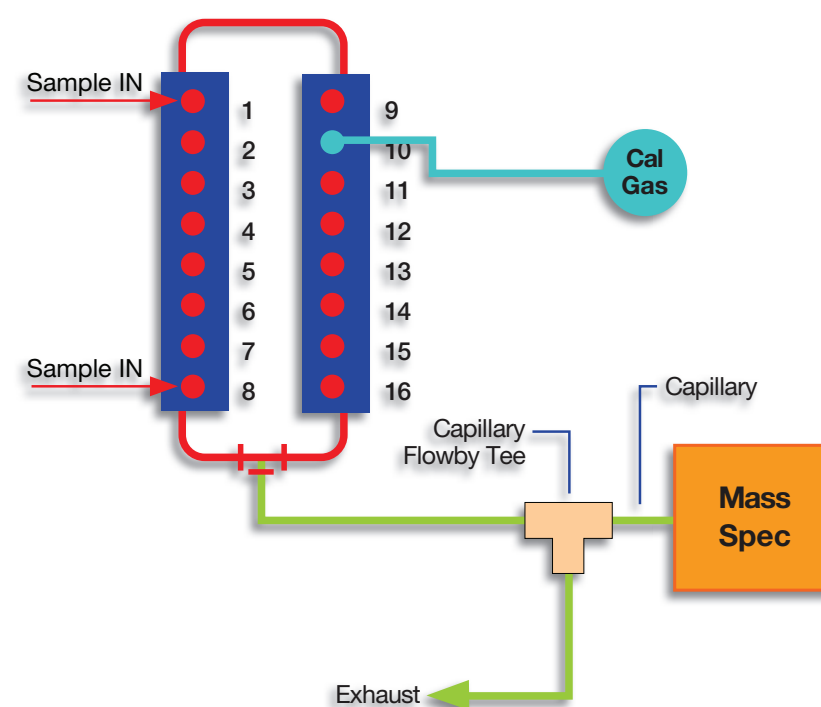

### APPLICATIONS

- Ammonia
- Ethylene
- Ethylene Oxide
- Polyethylene
- Steel Manufacturing, e.g., BOF, VOD
- Vinyl Chloride
- Syn Gas Production

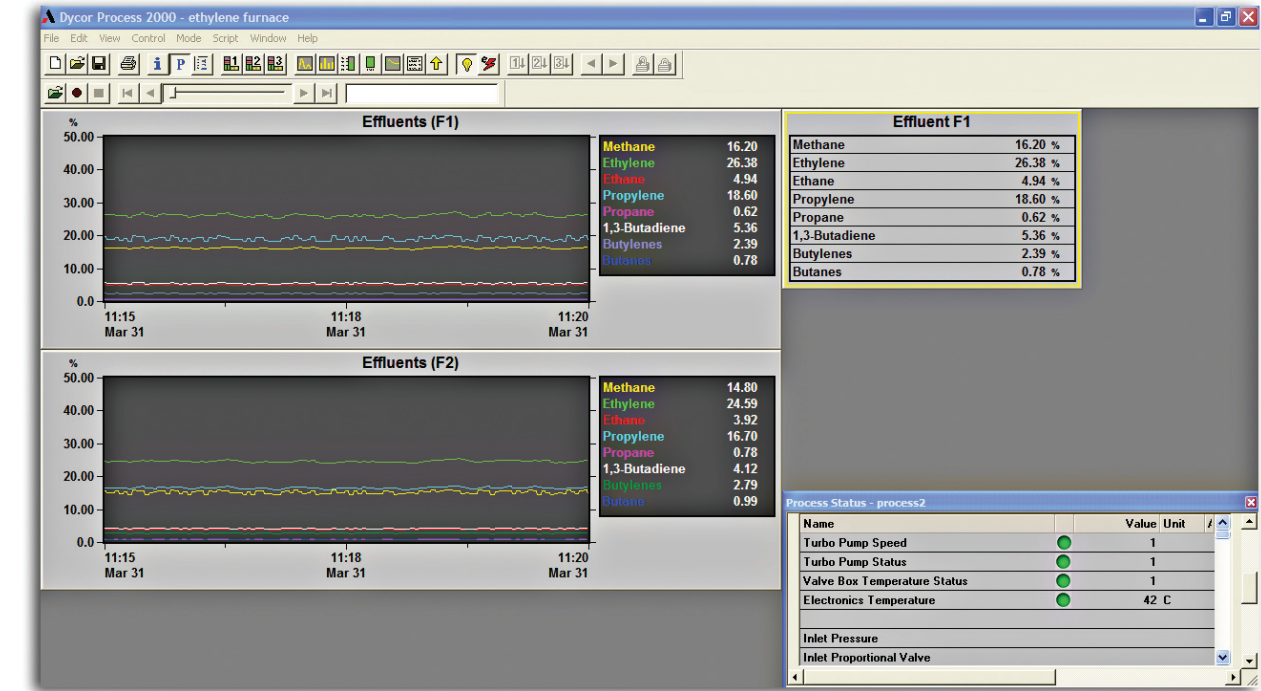

### PROCESS 2000 SOFTWARE

Process 2000 software is a powerful data acquisition tool and control package designed for automated operation of process mass spectrometers. It allows full user interaction and customization.

### SPECIFICATIONS

**Range:** 1-100 AMU; optional 1-200 AMU

**Inlet:** Expandable sample selection manifold with electric or pneumatic valves. Membrane inlet system for ambient air samples.

**Inlet Pressure (Gas):** 30 PSIG (207 kPa) to 3 Torr absolute.

**Accuracy:** Absolute Standard Deviation better than 25 PPM on 1% component, e.g., argon in air (0.25% RSD).

**Communication:** Ethernet standard (Optional: RS-485, RS-232, fiber optics, wireless radio, Modbus, OPC). Optional analog/digital outputs available.

**Detection Range:** From 10 PPM to 100% with gas samples, Faraday cup. Optional electron multiplier for lower LODs.

**Power:** 115/230 VAC, 50/60 Hz, 1000 W.

**Ambient Temperature:** +12°C to 40°C (water-cooled).

**PC:** On-board PC standard. Windows®-based Process 2000 Software can also be run on remote PC.

**Enclosure:** Weather resistant, stainless steel; ATEX and NEC purged, and designed for Cl D1 and 2 versions available.

**CE Compliance:** EN61326 EMC Directive and EN61010-1 Low Voltage Directive.

**ATEX Model Ratings:** II 2 G, EEx pd[ib] IIB+H2 T3, -15°C ≤ Ta ≤ 50°C.

