

# Dymaxion Mass Spectrometer

Offering the latest technology in gas analysis

## Features

- || No need to match electronics with analyzer head; offers maximum versatility.
- || Zero-drift, electrometer-amplifier technology provides repeatable data.
- || On-board diagnostics provides data integrity.
- || Optional on-board analog and digital I/O for monitoring and control of other sensor inputs.
- || RS-232 and RS-485 or Ethernet communication ports for local and network control.

## Description

The Dycor Dymaxion Residual Gas Analyzer (RGA) offers the latest quadrupole technology to provide unsurpassed gas analysis monitoring, characterization, or control for your application. Dymaxion RGAs are available in a choice of ion source (open, closed, enclosed) and AMU range (1-100, 1-200, and 1-300) to accommodate your needs.

## Software Features

- || Extensive systems integration capability with Visual Basic Scripting and DDE and OLE Automation.
- || Auto-Tune capabilities to ensure high-quality, repeatable data.
- || Real-Time Calculations can be applied to quadrupole or other input data.
- || Scripting Capabilities provide the power to automate equipment and process monitoring.
- || Spectral Interpretation suggests the gas species that could be contributing to your spectra.
- || Customized Displays can be created and saved without programming.
- || Optional Analog and Digital I/O for monitoring and control of your process.
- || Simulation Mode to facilitate user training and application development.

## Versatility

Dymaxion analyzer heads and electronics can be interchanged to provide maximum versatility.

## Software Upgrades

Dycor System 2000 software is a 32-bit, multi-threaded program developed to take full advantage of the capabilities of Windows XP, Vista and Windows 7, and is intended for real-time process control.

All Dycor analyzers, M/MA Series, System 1000, and QuadLinks can be upgraded to operate with Dycor System 2000 software for Windows XP, Vista and Windows 7. Existing customers can now protect their investment while maintaining compatibility with the Dymaxion line of RGAs. With a System 2000 upgrade, even the oldest Dycor analyzer can operate using the latest Windows software.

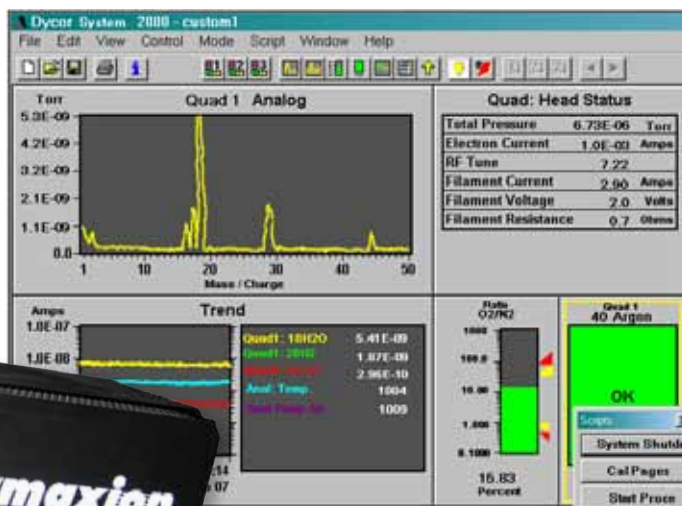

## Dymaxion Benchtop System

The Dymaxion Benchtop mass spectrometer is used for sampling gases over a wide range of pressures from high vacuum up to and beyond atmospheric pressure. The analyzer and inlet can be removed from the frame and placed up to ten feet from the pumping station using the included cable and vacuum hose. This system uses a Dymaxion mass spectrometer with choice of ion source, capillary inlet manifold, compound turbomolecular pump, dry or oil vane roughing pump, pump controller and optional laptop computer to run the System 2000 software. The analyzer can be designed for your specific application with a variety of options to meet your needs.



The Dycor Benchtop mass spectrometer can be configured specific to your application.

The Ethernet Dymaxion uses an Ethernet crossover CAT-5 cable plugged into an Ethernet port on the PC.



## Ethernet Dymaxion

The Ethernet Dymaxion provides all of the features of the standard Dymaxion RGA but is configured to allow Ethernet connection. The Ethernet Dymaxion software communicates directly to the PC using an Ethernet crossover CAT-5 cable plugged into an Ethernet port on the PC. Communication can also be established through a network (LAN) using a standard Ethernet cable between the Ethernet Dymaxion and the network. An Ethernet card must be installed in your PC to establish communication between the Ethernet Dymaxion and the PC.

The standard Dymaxion communicates using either an RS-232 serial port or an RS-485 communications port.



## Open Ion Source

- II Excellent for UHV and leak detection.
- II Simple design and construction reduces maintenance requirements.
- II Lowest-cost ionizer option.
- II **Applications Include:**  
HV and UHV systems; MBS systems; ion implant systems; load lock/transfer chambers; wafer preheat stations.

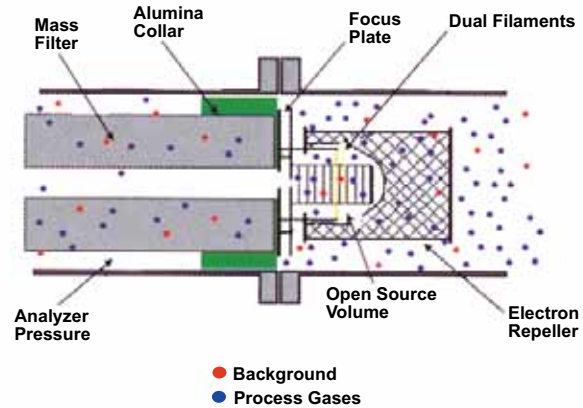

## Conductance Limited Source

- II Ideal for PVD applications.
- II Increases signal-to-noise by 100 times over the open ion source.
- II Background interferences are minimized because filament doesn't come in contact with the sample.
- II Works best with aprotic (non-hydrogen containing) gases.
- II **Applications Include:**  
PVD, sputter, high purity gas analysis.

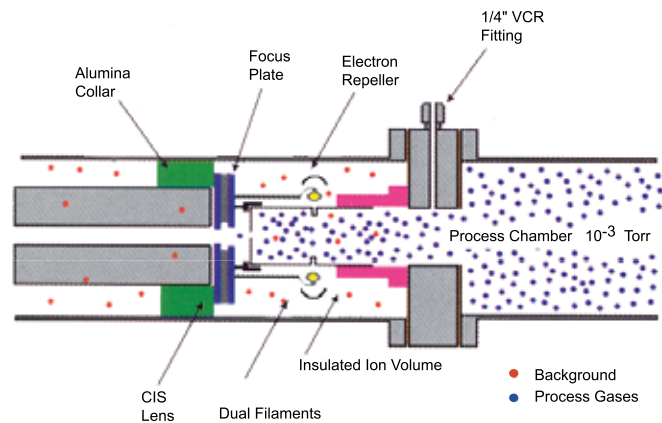

## Enclosed Ion Source

- II Excellent for CVD and atmospheric pressure sampling applications.
- II Can accommodate a wide range of sample inlet pressures.
- II Less pumping speed required than conductance limited source, lowering overall cost.
- II Works better than open and conductance limited sources in reactive gases.
- II No problems with hydrogen-containing gases.
- II **Applications Include:**  
CVD, vacuum furnaces, fermentation off-gas, atmospheric sampling, process stream sampling, etch, TGA.

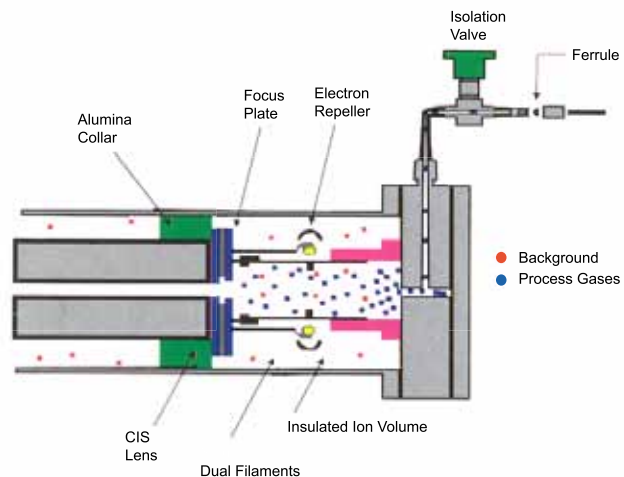

# Dymaxion Mass Spectrometer

## Performance Specifications

### Mass Range:

1-100, 1-200, 1-300 AMU

### Operating Pressure Range:

10-4 Torr to ultrahigh vacuum

### Minimum Detectable Partial Pressure:

5 x 10<sup>-12</sup> Torr ( 5 x 10<sup>-14</sup> Torr for electron multiplier units )

### Resolution:

Adjustable to constant peak width (0.5 AMU at 10% height)

### Emission Current:

0.1 to 10 mA; 50 mA to degas

### Electron Energy:

30 to 150 volts to operate; 200 volts to degas

### Ion Energy: 1 to 10 volts

### Source Sensitivity (Faraday Cup):

2 x 10<sup>-4</sup> Amps per Torr at detector (measured with nitrogen at mass 28) with peak width = 0.5 at 10% height and 1 x 10<sup>-3</sup> Amps emission current

### Power Requirements:

24 VDC @ 3 Amps; 110/220 VAC, 50/60 Hz adaptor available

### Stability:

*Mass Stability:* ± 0.1 AMU after 30 minute warm-up

*Peak Height:* ± 2% after 30 minute warm-up

### Minimum PC Requirements:

Pentium microprocessor or compatible, with Windows 98, ME, NT, 2000, XP, Vista or Windows 7

### RS-232 Serial Communications Interface:

Isolated; baud rate selection of 1200 to 38,400; 9-pin, female D-connectors

### RS-485 Addressable Communications Interface:

Isolated, baud rate selection of 1200 to 38,400; programmable addresses; 2-pin, female D-connectors

### Optional Analog/Digital I/O Board:

Includes two analog inputs, two analog outputs, six relay contact closures, and four digital inputs

### Physical Dimensions

*Weight:* 4.6 lb (2.1 kg) without head  
74. lb (3.4 kg) with head

*Width:* 4.5 in. (11.4 cm)

*Length:* 9.0 in. (22.9 cm)

*Height:* 5.25 in. (13.3 cm)

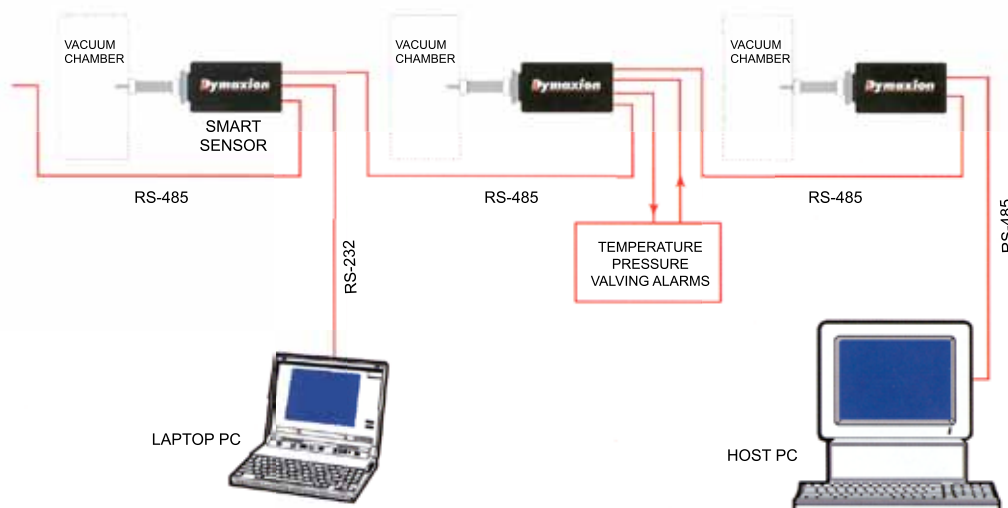

Use a laptop to control a single analyzer or use an RS-485 network to control multiple analyzers and analog, digital I/O. With the System 2000 software, any number of analyzers can be linked for true simultaneous data acquisition and control from one PC.

**AMETEK**  
PROCESS INSTRUMENTS

150 Freeport Road, Pittsburgh, PA 15238  
Ph. +1-412-828-9040, Fax +1-412-826-0399  
[www.ametekpi.com](http://www.ametekpi.com)



© 2011, by AMETEK, Inc.  
All rights reserved. Printed in the U.S.A.  
F-0210 Rev. 3 (0111)

One of a family of innovative process analyzer solutions from AMETEK Process Instruments.  
Specifications subject to change without notice.

### SALES AND MANUFACTURING:

**USA - Delaware**  
455 Corporate Blvd., Newark DE 19702 • Tel: +1-302-456-4400, Fax: +1-302-456-4444

**USA - Oklahoma**  
2001 N. Indianwood Ave., Broken Arrow OK 74012 • Tel: +1-918-250-7200, Fax: +1-918-459-0165

**CANADA - Alberta**  
2876 Sunridge Way N.E., Calgary, AB T1Y 7H9 • Tel: +1-403-235-8400, Fax: +1-403-248-3550

### WORLDWIDE SALES AND SERVICE LOCATIONS:

**USA - Texas**  
Tel: +1-713-466-4900, Fax: +1-713-849-1924

**CHINA**  
Beijing / Tel: 86 10 8526 2111, Fax: 86 10 8526 2141  
Chengdu / Tel: 86 28 8675 8111, Fax: 86 28 8675 8141  
Guangzhou / Tel: 86 20 8363 4768, Fax: 86 20 8363 3701  
Shanghai / Tel: 86 21 5868 5111, Fax: 86 21 5866 0969

**FRANCE**  
Tel: 33 1 30 68 89 20, Fax: 33 1 30 68 89 29

**GERMANY**  
Tel: 49 21 59 91 36 0, Fax: 49 21 59 91 3639

**INDIA**  
Tel: 9180 6782 3200, Fax: 9180 6782 3232

**SINGAPORE**  
Tel: 65 6484 2388, Fax: 65 6481 6588

DYCOR