

# ta3000R Method A-001

## Determination of Trace Levels of H<sub>2</sub> and CO in the Atmosphere

### Introduction

TheTrace Analytical™ ta3000R Reduction Gas Analyzer is ideally suited for the determination of ppb to ppm levels of H<sub>2</sub> and CO in atmospheric studies. CO is involved in ozone depletion, even at very low concentrations. In this analysis, the Reduction Gas Detector (RGD) is used to provide rapid and reproducible measurements. Several unique qualities of the RGD enable the quantitation of H<sub>2</sub> and CO to extremely low concentrations.

This system was designed for trace levels of H<sub>2</sub> and CO in the atmosphere, where there is a possibility of other high molecular weight pollutants that could interfere with the determination.

### The Trace Analytical Method

The flow diagram for method A-001 is shown in Figure 1. Air carrier gas is preferred because it gives a minimum of upset in the baseline from the injection, is inexpensive and readily available.

A 10-port valve is used to inject samples from the sample loop to the stripper column 1. Lighter compounds such as H<sub>2</sub> and CO elute quickly from the stripper column into the analytical column 2, while higher molecular weight components such as hydrocarbons and moisture elute very slowly from the stripper column. After the light components have had sufficient time to elute from the stripper column into the analytical column, the 10-port valve returns

to the load position. In addition to preparing the analyzer for the next sample injection, the valve in this position is used to backflush the higher molecular weight components from the stripper column to vent.

Backflushing of the stripper column accomplishes two objectives. It shortens the analysis time and it vents contaminants which can produce an unstable baseline away from the detector. O<sub>2</sub> and N<sub>2</sub> from the air will elute through the analytical column. However these components do not interfere with the determination of H<sub>2</sub> and CO because of the chromatography and the selectivity of the RGD.

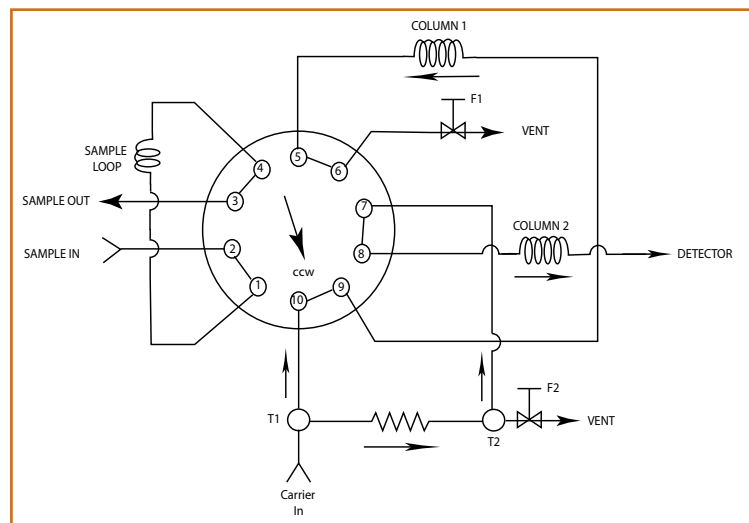
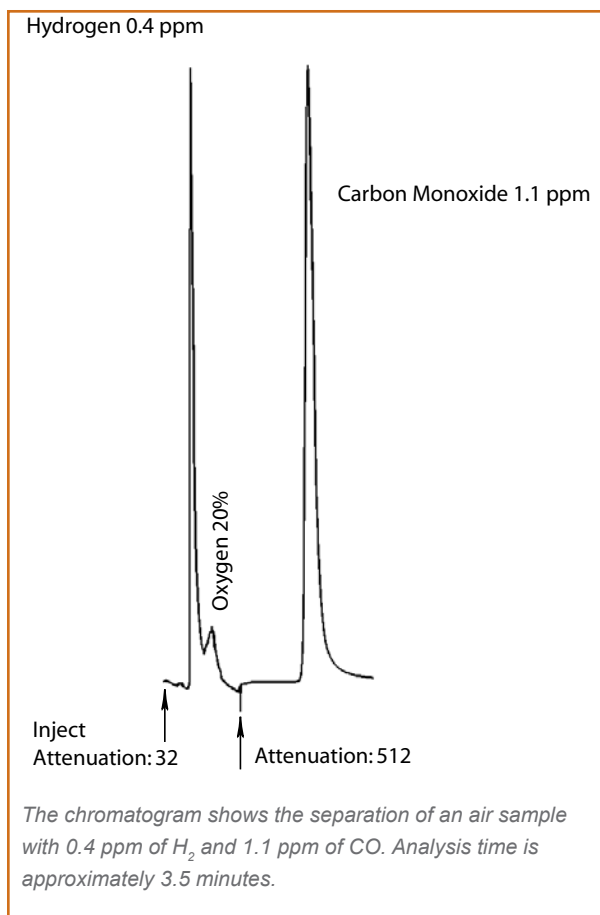

Figure 1. Flow diagram for method A-001.



Method A-001 is one of several application packages developed by Trace Analytical. Our applications group is always ready to consult with you about your specific analytical requirements. Please contact AMETEK Process Instruments or your local AMETEK representative for information on our Trace Analytical analyzers.

**AMETEK**®  
PROCESS INSTRUMENTS

455 Corporate Blvd., Newark, DE 19702  
Ph. +1-302-456-4400, Fax +1-302-456-4444  
www.ametekpi.com

REGISTERED  
**ISO 9001**  
MANAGEMENT SYSTEM

© 2011, by AMETEK, Inc.  
All rights reserved. Printed in the U.S.A.  
F-0238 Rev. 2 (0311)

One of a family of innovative process analyzer solutions from AMETEK Process Instruments.  
Specifications subject to change without notice.

**SALES AND MANUFACTURING:**

**USA - Oklahoma**  
2001 N. Indianwood Ave., Broken Arrow OK 74012 • Tel: +1-918-250-7200, Fax: +1-918-459-0165

**USA - Pennsylvania**  
150 Freeport Road, Pittsburgh PA 15238 • Tel: +1-412-828-9040, Fax: +1-412-826-0399

**CANADA - Alberta**  
2876 Sunridge Way N.E., Calgary, AB T1Y 7H9 • Tel: +1-403-235-8400, Fax: +1-403-248-3550

**WORLDWIDE SALES AND SERVICE LOCATIONS:**

**USA - Texas**  
Tel: +1-713-466-4900, Fax: +1-713-849-1924

**CHINA**  
Beijing / Tel: 86 10 8526 2111, Fax: 86 10 8526 2141  
Chengdu / Tel: 86 28 8675 8111, Fax: 86 28 8675 8141  
Guangzhou / Tel: 86 20 8363 4768, Fax: 86 20 8363 3701  
Shanghai / Tel: 86 21 5868 5111, Fax: 86 21 5866 0969

**FRANCE**  
Tel: 33 1 30 68 89 20, Fax: 33 1 30 68 89 29

**GERMANY**  
Tel: 49 21 59 91 36 0, Fax: 49 21 59 91 3639

**INDIA**  
Tel: 91 80 6782 3200, Fax: 91 80 6782 3232

**SINGAPORE**  
Tel: 65 6484 2388, Fax: 65 6481 6588