

AMETEK Model 5100HD Verification / Validation

Background

Sensors used in analyzer systems come in to direct contact with the process gas, and there is the potential for sensor degradation over a period of time especially with streams that contain contaminants like glycol, moderate to high levels of hydrogen sulfide etc. With sensor degradation, the analyzer response characteristics change resulting in inaccurate readings.

In order to address this problem, the analyzer is periodically challenged with a known external reference

sample or internally generated traceable gas sample and necessary adjustments to the calibration are made (as long as the deviation in analyzer response from the known, expected concentration is within predefined limits). If the analyzer response is not within the specified limits, the analyzer output is considered invalid and an alarm is triggered. If the alarm condition persists, the sensor is either repaired or replaced.

AMETEK 5100HD TDLAS Analyzer

In the case of the AMETEK 5100HD TDLAS (Tunable Diode Laser Absorption Spectroscopy) system, neither the laser source nor the detector element come in to contact with the process gas and, therefore, there is no change in the system response relative to the sensor contamination issues described above. However, it is very important for the end user to know that the analyzer system is performing properly and that the results are accurate and valid. While the analyzer with a non-contact sensor may see little or no degradation, often it is the sample conditioning that introduces analysis errors and therefore needs validation.

AMETEK 5100HD TDLAS uses two methods to guarantee users the level of comfort they need to have about their analyzer. One is the built-in verification that insures the integrity of the analyzer performance (making sure the analyzer is working the way it is intended). The second method is the calibration validation where a known challenge (bottled gas etc.) can be introduced on demand or periodically to validate the analyzer calibration. The second method tests the whole analyzer system (analyzer and the sample conditioning) and eliminates sample conditioning induced errors.



Built-in verification and validation

Verification

A key feature of this instrument is the use of sealed reference cells, which contain known amounts of analyte gases measured, for referencing the emission wavelengths of the lasers. Primarily, the use of reference cells enables the ability to line-lock the laser. Any minor shifts in the observed peaks are used as feedback to lock the laser at the peak center. This way we have real time confirmation that the laser is locked on the absorption line. Also, the calculated value of the analyte concentration in the reference cell is used as a check to confirm the analyzer response.

Validation

The analyzer is also configured for field calibration validation and users can challenge the analyzer response (single point span check) with a known sample such as bottled gas. If the analyzer response is within acceptable limits, necessary adjustments are made to the calibration parameters. If it is not, the data is declared invalid and a data invalid alarm is triggered.

Summary

The above two features make the AMETEK Model 5100HD truly robust in its performance and reliability. The unique performance verification approach designed into the Model 5100HD provides a real-time indication that the system

is performing properly and that the reported concentration results for the gas stream are valid. The calibration validation feature provides the user comfort in knowing that the analyzer results are accurate.

Reference Cell Schematic

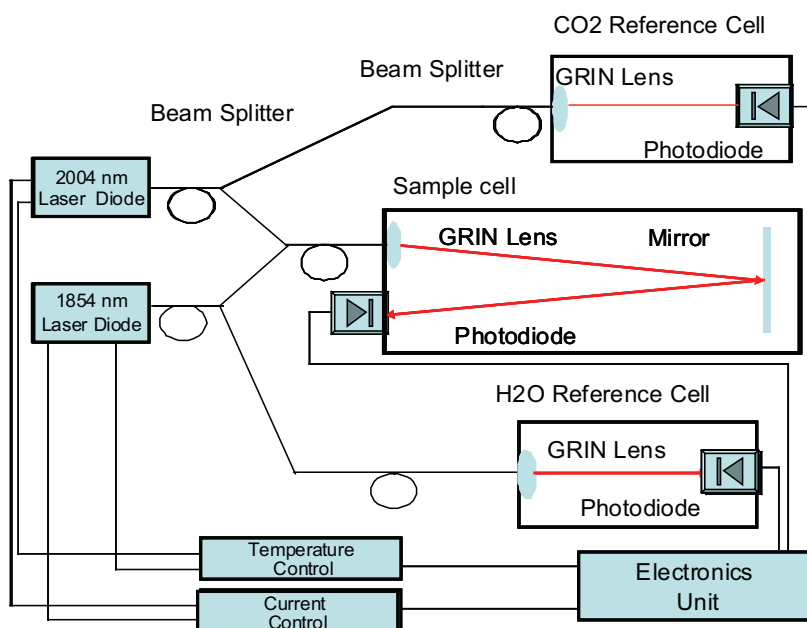

150 Freeport Road, Pittsburgh, PA 15238
Ph. +1-412-828-9040, Fax +1-422-826-0399
www.ametekpi.com



© 2011, by AMETEK, Inc.
All rights reserved. Printed in the U.S.A.
F-0140 Rev. 3 (0411)

One of a family of innovative process analyzer solutions from AMETEK Process Instruments.
Specifications subject to change without notice.

SALES AND MANUFACTURING:

USA - Delaware
455 Corporate Blvd., Newark DE 19702 • Tel: +1-302-456-4400, Fax: +1-302-456-4444

USA - Oklahoma
2001 N. Indianwood Ave., Broken Arrow OK 74012 • Tel: +1-918-250-7200, Fax: +1-918-459-0165

CANADA - Alberta
2876 Sunridge Way N.E., Calgary, AB T1Y 7H9 • Tel: +1-403-235-8400, Fax: +1-403-248-3550

WORLDWIDE SALES AND SERVICE LOCATIONS:

USA - Texas
Tel: +1-713-466-4900, Fax: +1-713-849-1924

CHINA
Beijing / Tel: 86 10 8526 2111, Fax: 86 10 8526 2141
Chengdu / Tel: 86 28 8675 8111, Fax: 86 28 8675 8141
Guangzhou / Tel: 86 20 8363 4768, Fax: 86 20 8363 3701
Shanghai / Tel: 86 21 5868 5111, Fax: 86 21 5866 0969

FRANCE
Tel: 33 1 30 68 89 20, Fax: 33 1 30 68 89 29

GERMANY
Tel: 49 21 59 91 36 0, Fax: 49 21 59 91 3639

INDIA
Tel: 91 80 6782 3200, Fax: 91 80 6782 3232

SINGAPORE
Tel: 65 6484 2388, Fax: 65 6481 6588