

ProLine-RQ™ Process Mass Spectrometer

Online Gas Analysis for Bioreactors

Benefits in Fermentation

- || Product quality improvement
- || Real-time tracking of gas composition
- || Online measurement of all components in the gas phase
- || Display RQ along with individual gas concentrations
- || Monitor multiple fermenters at the same time
- || More accurate mass balance
- || Detection of abnormal growth
- || Replace discrete analytical devices
- || Low sample flow rates (typically < 50 ml/min)

Quantitative Analysis in a Compact Package

Along with the increase in complexity of biotechnology products manufactured by fermentation, comes the need for fast, accurate online process gas analysis.

The characteristic growth curve of a culture (and thus the biomass

growth rate) changes throughout the fermentation process and with it, the oxygen uptake requirement of the living microorganism. Regulation of the oxygen uptake is essential since either oxygen deficiency or too high a concentration of oxygen in the medium can cause unwanted changes in metabolism. The ratio of carbon dioxide production to oxygen uptake is known as the Respiratory Quotient (RQ) and is a measure of the metabolic activity of the microorganism.

AMETEK's ProLine process mass spectrometer offers a continuous measurement of bioreactor off gases including O₂, CO₂, N₂, Ar and alcohols, as well as contaminants, providing a specific method for determining whether to stop or continue fermentation of the microorganism culture.

Multicomponent, Multistream

The multiport sample inlet system consists of 8 or 16 manifold-mounted valves and a capillary restriction in an enclosure heated to prevent condensation. Analysis of multiple components and the ability



The ProLine-RQ comes complete with sub-atmospheric sampling system, automatic valve switching, and pumping station, with room for additional I/O capability.

to sample up to 16 streams, allows one ProLine to monitor and control several reactors at the same time. Typical sample flow rates can be much less than 50 ml/min, allowing sampling of microliter volumes with limited headspace. The software provides real-time calculation of RQ and provides the information necessary to maximize culture health and productivity.

Growth Curve of a Culture

Bacteria and yeasts possess an exceptionally high metabolic activity rate and under the right conditions multiply very rapidly. The growth of a microorganism fermentation over time consists of four phases.

- || In the lag phase, the microorganism acclimatizes to the new environment.
- || In the exponential phase, it reaches maximum growth.
- || In the stationary phase, as a rule, no further propagation takes place.
- || In the decay stage, the microorganism begins to die since the energy reserves of the cells are exhausted.

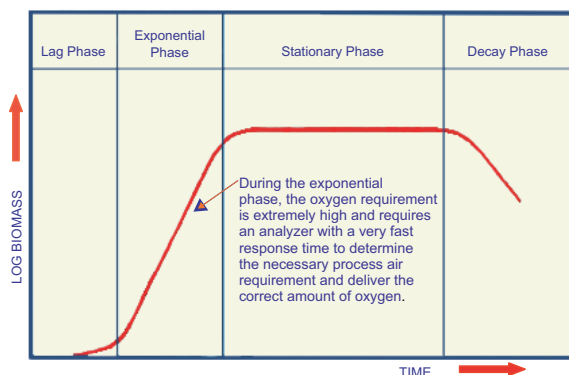
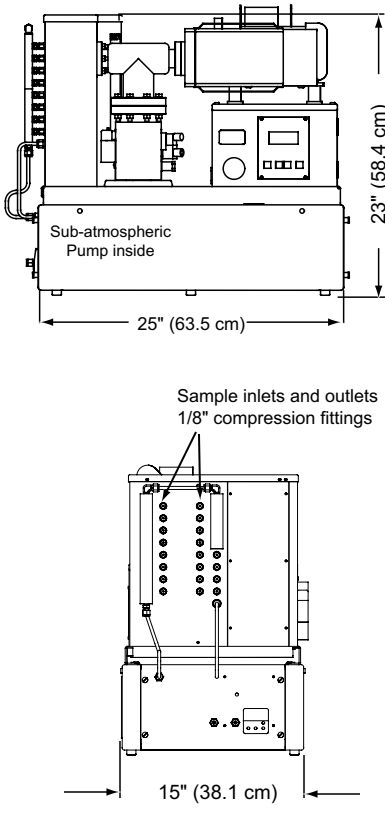

Figure 1. The progress of the fermentation is determined by analysis of the composition of the reactor off-gas, particularly the residual O₂ and CO₂ concentrations. The addition of input and exhaust flow values provides the most accurate RQ value.

ProLine-RQ Process Mass Spectrometer

PROLINE™



Specifications

Range: 1-100 AMU. Optional: 1-200 AMU, 1-300 AMU.

Sample Ports: 8- or 16-way stream selection manifold

Inlet Pressure: 20 PSIG to 650 Torr absolute (138 to 86 kPa)

Accuracy: Better than 0.5% of measured value for argon in air

Outputs: RS-485, RS-232, optional 4-20mA

Detection Range: From 10 PPM to 100%

Power: 115/230 VAC, 50/60 Hz, 500W

PC Requirements: Pentium® equivalent, 600MHz or better, Windows 98, ME, NT, 2000 or XP

Enclosure: General purpose benchtop; optional weatherproof version available.

Dimensions: 25" x 15" x 23" (63.5 cm. x 38 cm. x 58.4 cm.)

Weight: 100 lb. (45 kg.)

Applications

- || Recombinant DNA, genetic engineering
- || Antibiotics, vitamins, toxins, vaccines
- || Hormones, monoclonal antibodies
- || Proteins, antigens
- || Cell culture
- || Microliter chambers with limited headspace

Easy to Use and Maintain

AMETEK has more than 20 years of experience in mass spectrometer design and manufacture, with many thousands of analyzers already operating reliably. At the heart of the ProLine mass spectrometer is the proven AMETEK quadrupole mass filter, with excellent stability, sensitivity and resolution across the whole mass range. The software provides easy set-up and operation and includes advanced alarm and automation capabilities. Autocalibration maintains the performance and accuracy of the system for quantitative analysis. Self-diagnostics and modular design ensure ease of maintenance by your own personnel on site, with modem support available for additional factory diagnosis and troubleshooting.

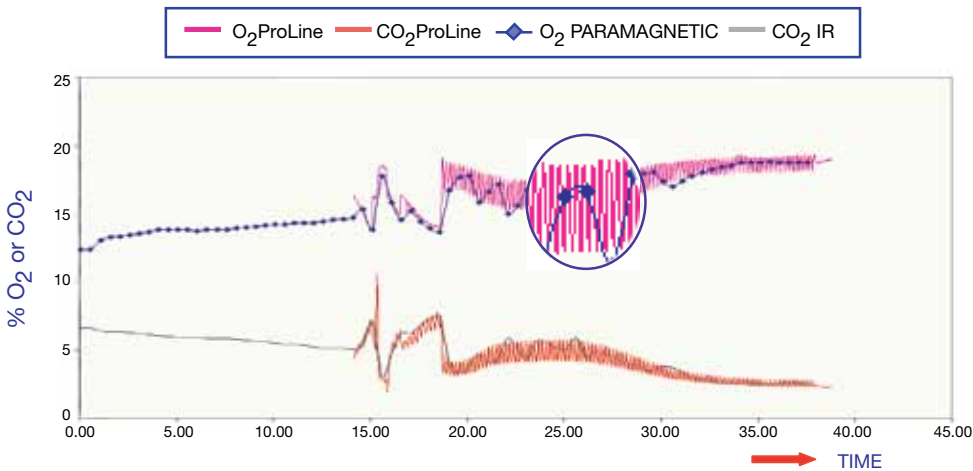

Figure 2. Real-Time Response

Bioreactors are frequently equipped with paramagnetic oxygen analyzers, non-dispersive infrared carbon dioxide analyzers and/or dissolved probes. The real-time response of the ProLine clearly shows the rapid change in O₂ and CO₂ that can occur in the fermentation process. Being able to see the changes provides valuable information about the process and will lead to tighter and more reproducible process control. This single, multicomponent, multipoint analyzer continuously provides data missed by slower instruments



150 Freeport Road, Pittsburgh, PA 15238
Ph. +1-412-828-9040, Fax +1-412-826-0399
www.ametekpi.com



© 2011, by AMETEK, Inc.
All rights reserved. Printed in the U.S.A.
F-0365 Rev. 1 (0611)

One of a family of innovative process analyzer solutions from AMETEK Process Instruments.
Specifications subject to change without notice.

SALES AND MANUFACTURING:

USA - Delaware
455 Corporate Blvd., Newark DE 19702 • Tel: +1-302-456-4400, Fax: +1-302-456-4444

USA - Oklahoma
2001 N. Indianwood Ave., Broken Arrow OK 74012 • Tel: +1-918-250-7200, Fax: +1-918-459-0165

CANADA - Alberta
2876 Sunridge Way N.E., Calgary, AB T1Y 7H9 • Tel: +1-403-235-8400, Fax: +1-403-248-3550

WORLDWIDE SALES AND SERVICE LOCATIONS:

USA - Texas
Tel: +1-713-466-4900, Fax: +1-713-849-1924

CHINA
Beijing / Tel: 86 10 8526 2111, Fax: 86 10 8526 2141
Chengdu / Tel: 86 28 8675 8111, Fax: 86 28 8675 8141
Guangzhou / Tel: 86 20 8363 4768, Fax: 86 20 8363 3701
Shanghai / Tel: 86 21 5868 5111, Fax: 86 21 5866 0969

FRANCE
Tel: 33 1 30 68 89 20, Fax: 33 1 30 68 89 29

GERMANY
Tel: 49 21 59 91 36 0, Fax: 49 21 59 91 3639

INDIA
Tel: 91 80 6782 3200, Fax: 91 80 6782 3232

SINGAPORE
Tel: 65 6484 2388, Fax: 65 6481 6588