

MGB1000

Micro Gas Blender

Introduction

Gas analyzers need to be calibrated accurately in order to quantitatively measure the components of interest in unknown samples. The fundamental challenge with an analytical system designed for trace analysis is the ability to do accurate quantitation close to the signal to noise level of the detector. To meet this challenge, it is essential to calibrate the measuring device as close as possible to the expected sample concentration. Calibrating at ppm concentrations could bias the sample analysis when analyzing samples at ppb levels.

It is impractical to specify accurate calibration standards at low ppb levels. Components at trace levels do interact with the surfaces of the gas cylinder, hence the actual value of the standard will vary widely from cylinder to cylinder. A better approach is to take a ppm calibration standard down to ppb concentrations with a diluent or zero gas using a gas blender just upstream of the analyzer. Generating trace level calibration gas standards with an external blender ensures high accuracy and may provide long term savings.

Capillary Orifice Blender

The Trace Analytical™ MGB1000 Micro Gas Blender, manufactured by AMETEK Process Instruments, is a capillary orifice blender that provides higher accuracy while consuming less zero and calibration gas in comparison to mass flow control (MFC) type blenders. Also, the MGB1000 does not need frequent recalibration. It is a versatile blender that can be used for calibration and certification of a variety of gas analysis instrumentation. Figure 1 shows the flow diagram of the blender.

The relationship between flow rate and pressure drop across capillary orifices R_c and R_z are precisely known. Electronic pressure gauges (G1-G3) indicate the pressure drops across R_c and R_z . The actual flow rates of zero (F_z) or diluent gas and calibration (F_c) gas are obtained using a look-up table, relating pressure and flow. Back pressure regulators (BPR1 and BPR2) control the pressure drops across R_c/R_z and therefore blend ratios. The pressure of the blended gas stream delivered to an analyzer is controlled by BPR2. Each back pressure regulator is located on a vent line to prevent contaminants from entering the blended flow path.

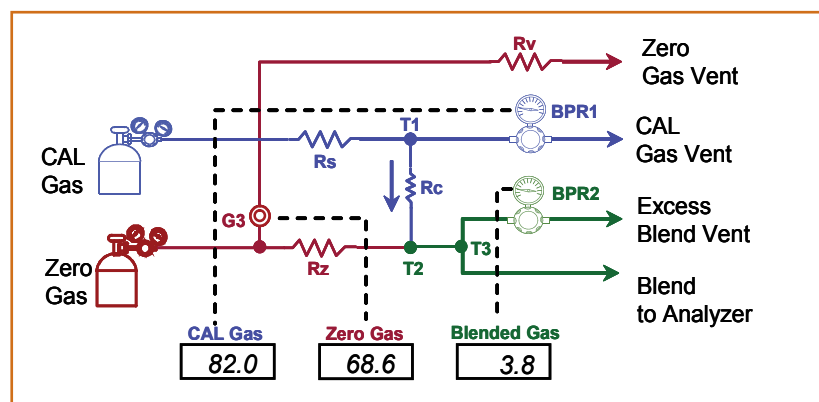

Figure 1. Blender flow diagram.

Long term accuracy of this blending method is derived from the inherent repeatability (+ 0.05% full scale) and long term stability (+ 0.1% full scale/year) of the pressure transducers used in determining capillary flow rates. The entire volume of the blended gas path is less than 500 µL. Because of extremely low internal volumes, the time required to achieve a desired blend ratio after changing the pressures is minimal. Small internal diameter tubing also achieves maximum sweep rate for minimum out gassing.

The MGB1000 Micro Gas Blender is designed to generate consistent and reliable fixed-point or

variable gas concentrations at blend ratios from 4:1 up to 4545:1. This means that a calibration standard at 5 ppm, consisting of either a single component or a mixture of components, diluted into a major diluent gas, can be blended down reliably to less than 1 ppb. The blender can be employed for both ppm and ppb levels of the components of interest. Figure 2 shows a calibration curve for methane blended in nitrogen and illustrates the capabilities of the MGB1000 blender in terms of linearity and accuracy of ppb blends.

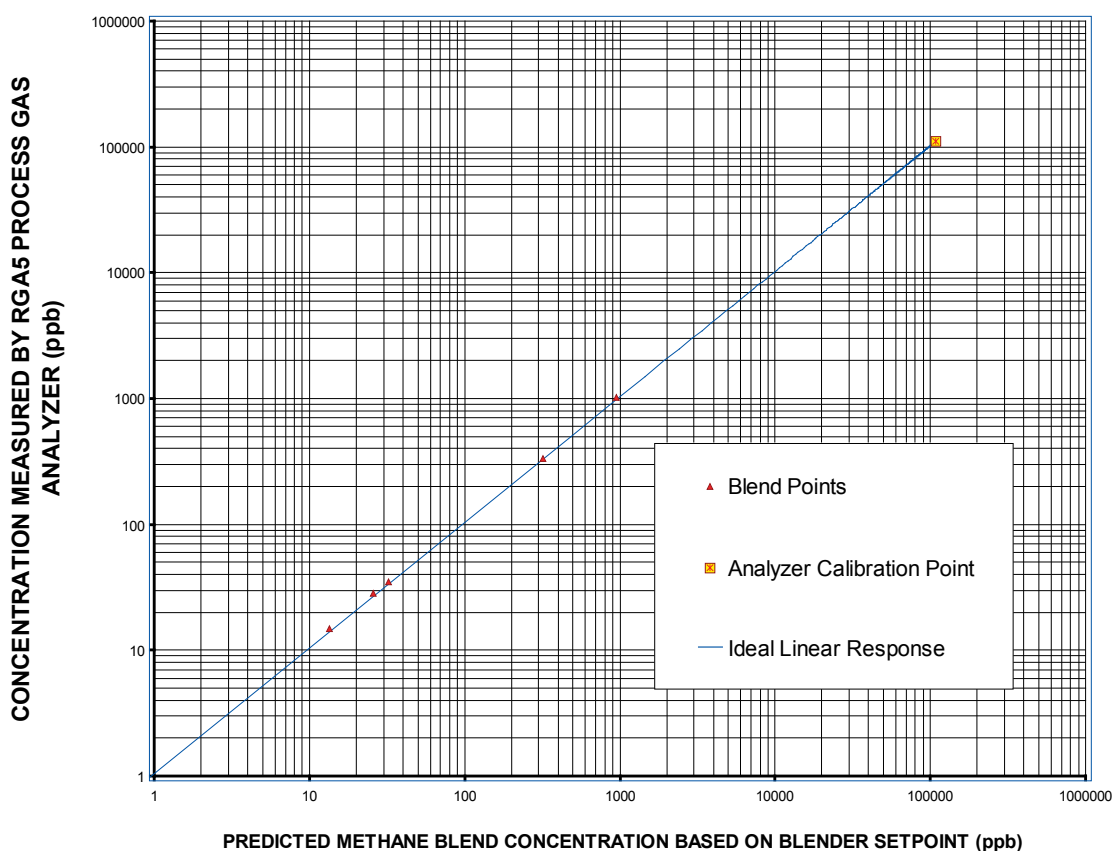

Figure 2. Calibration curve for methane blended in nitrogen.



455 Corporate Blvd., Newark, DE 19702
Ph. +1-302-456-4400, Fax +1-302-456-4444
www.ametekpi.com



© 2011, by AMETEK, Inc.
All rights reserved. Printed in the U.S.A.
F-0237 Rev. 2 (0311)

One of a family of innovative process analyzer solutions from AMETEK Process Instruments.
Specifications subject to change without notice.

SALES AND MANUFACTURING:

USA - Oklahoma
2001 N. Indianwood Ave., Broken Arrow OK 74012 • Tel: +1-918-250-7200, Fax: +1-918-459-0165

USA - Pennsylvania
150 Freeport Road, Pittsburgh PA 15238 • Tel: +1-412-828-9040, Fax: +1-412-826-0399

CANADA - Alberta
2876 Sunridge Way N.E., Calgary, AB T1Y 7H9 • Tel: +1-403-235-8400, Fax: +1-403-248-3550

WORLDWIDE SALES AND SERVICE LOCATIONS:

USA - Texas
Tel: +1-713-466-4900, Fax: +1-713-849-1924

CHINA
Beijing / Tel: 86 10 8526 2111, Fax: 86 10 8526 2141
Chengdu / Tel: 86 28 8675 8111, Fax: 86 28 8675 8141
Guangzhou / Tel: 86 20 8363 4768, Fax: 86 20 8363 3701
Shanghai / Tel: 86 21 5868 5111, Fax: 86 21 5866 0969

FRANCE
Tel: 33 1 30 68 89 20, Fax: 33 1 30 68 89 29

GERMANY
Tel: 49 21 59 91 36 0, Fax: 49 21 59 91 3639

INDIA
Tel: 91 80 6782 3200, Fax: 91 80 6782 3232

SINGAPORE
Tel: 65 6484 2388, Fax: 65 6481 6588