

ta3000R Method W-001

Determination of H₂ in Ground Water as a Marker for Anaerobic Bacteria

Introduction

Because of its selectivity and sensitivity, the Trace Analytical™ ta3000R Reduction Gas Analyzer, from AMETEK Process Instruments, is ideally suited for the determination of ppb levels of H₂ in groundwater.

H₂ is an indicator for the quantity of anaerobic bacteria and contamination of organic material in ground water as well as in soil saturated with water. In the water there are anaerobic, fermentative bacteria as well as aerobic species that feed on organics, such as petroleum oil and land fill leachates. There is competition between the various kinds of bacteria. Depending upon local environmental conditions, there is a preponderance of one kind over the other. In general, the aerobes exhibit a faster degradation rate of organic material as compared to the anaerobes. A high H₂ content from the anaerobes is associated with reducing conditions which also inhibits aerobic bacteria.

The anaerobic bacteria consume the contaminants and release H₂ which can be measured with the very sensitive ta3000R gas analyzer. The amount of H₂ is a marker for the anaerobic bacteria and the amount of organic contamination. Since the concentration of H₂ in the water is in the order of 1-50 ppt, it is important to concentrate the gas before analysis, and to use a very sensitive detector such as the Reduction Gas Detector (RGD). There is presently a lot of research going on in this area and the future will see more analyses being done. The intent is to eventually use specific bacteria for specific organic contamination and to alter the local environment for maximum degradation of the organics.

Sampling

Since the bacteria are anaerobes, they can not be exposed to oxygen. Sampling is therefore done without any air contamination. A well drilled from 20 ft. to 150 ft. depth is encased with a 2 in. diameter PVC pipe. A positive displacement pump is lowered to the bottom of the well with a tube connected to a 250 mL glass container with stopcocks at both ends. The glass container has a glass nipple located in the middle of the body fitted with a silicon rubber septum (see Figure 1).

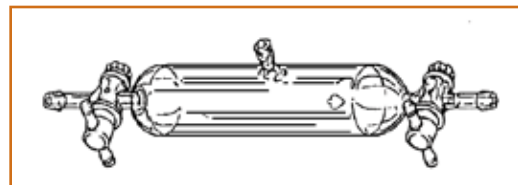

Figure 1. Glass collecting tube.

H₂ in Groundwater as a Marker for Anaerobic Bacteria

Water is continuously pumped through the container and a 5-20 mL bubble of nitrogen is injected into the container through the septum with a gas tight syringe. The nitrogen bubble stays in place even though the water is flowing past it in the container at a fixed flow rate.

H₂ equilibrates instantly between the water and the nitrogen bubble. At fixed intervals a gas sample of 1-2 mL is withdrawn with the gas tight syringe from the bubble and injected into the sample loop of the ta3000R analyzer. After filling the loop, the valve is actuated and the sample analyzed for

the H₂ content. The headspace technique concentrates the H₂ from ppt levels in the water to ppb in the nitrogen bubble which can conveniently be detected by the ta3000R. Alternatively a single sample can be analyzed. A water sample is collected in the same container, the stopcocks are closed and a 2 mL nitrogen bubble injected that is analyzed by the ta3000R analyzer.

short analysis time for H₂. After the elution of H₂ any remaining components in the column are back-flushed to vent, assuring no interference with the next sample.

Method W-001 is one of several application packages developed by Trace Analytical. Our applications group is always ready to consult with you about your specific analytical requirements. Please contact AMETEK Process Instruments or your local AMETEK representative for information on our Trace Analytical analyzers.

Instrumentation

The recommended column and valve configuration for the ta3000R analyzer is the W-001 system. This configuration gives

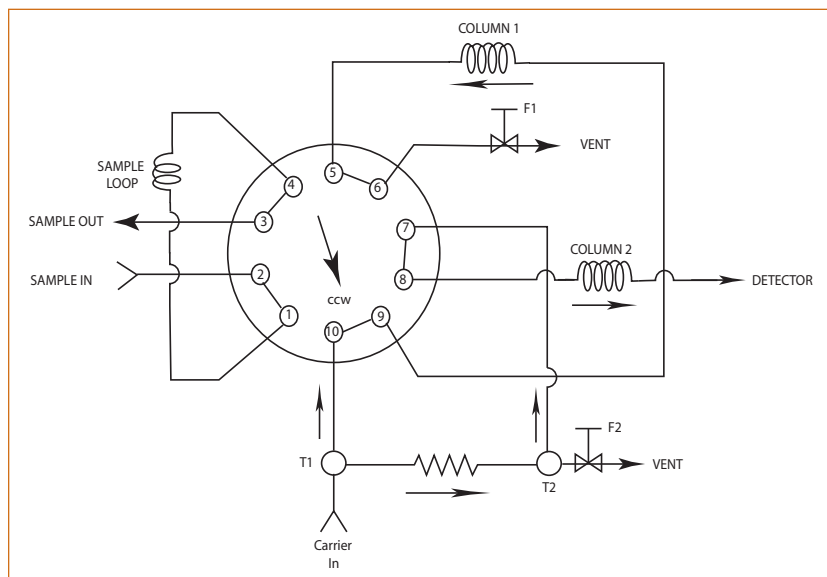

Figure 2. Flow diagram for method W-001.

AMETEK®
PROCESS INSTRUMENTS

455 Corporate Blvd., Newark, DE 19702
Ph. +1-302-456-4400, Fax +1-302-456-4444
www.ametekpi.com



© 2010 by AMETEK, Inc.
All rights reserved. Printed in the U.S.A.
F-0336 Rev 1 (1210)

One of a family of innovative process analyzer solutions from AMETEK Process Instruments.
Specifications subject to change without notice.

SALES AND MANUFACTURING:

USA - Oklahoma
2001 N. Indianwood Ave., Broken Arrow OK 74012 • Tel: +1-918-250-7200, Fax: +1-918-459-0165
USA - Pennsylvania
150 Freeport Road, Pittsburgh PA 15238 • Tel: +1-412-828-9040, Fax: +1-412-826-0399
CANADA - Alberta
2876 Sunridge Way N.E., Calgary, AB T1Y 7H9 • Tel: +1-403-235-8400, Fax: +1-403-248-3550

WORLDWIDE SALES AND SERVICE LOCATIONS:

USA - Texas
Tel: +1-713-466-4900, Fax: +1-713-849-1924
CHINA
Beijing / Tel: 86 10 8526 2111, Fax: 86 10 8526 2141
Chengdu / Tel: 86 28 8675 8111, Fax: 86 28 8675 8141
Guangzhou / Tel: 86 20 8363 4768, Fax: 86 20 8363 3701
Shanghai / Tel: 86 21 5868 5111, Fax: 86 21 5866 0969
FRANCE
Tel: 33 1 30 68 89 20, Fax: 33 1 30 68 89 29
GERMANY
Tel: 49 21 59 91 36 0, Fax: 49 21 59 91 36 39
INDIA
Tel: 91 80 6782 3200, Fax: 91 80 6782 3232
SINGAPORE
Tel: 65 6484 2388, Fax: 65 6481 6588