

SAFETY MANUAL

Thermax WDG-V Combustion Analyzer

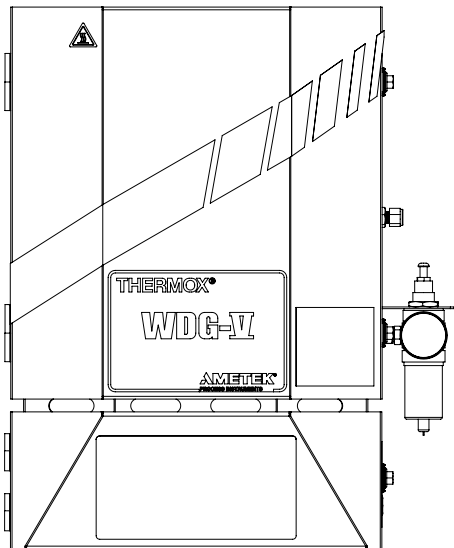

THIS DOCUMENT CONTAINS CONFIDENTIAL INFORMATION.
Its use is restricted to employees with a need to know and third parties with a need to know and who have signed a non-disclosure agreement.

Copyright Notice © 2023 AMETEK Process Instruments. All rights reserved.

The information and descriptions in this document are the sole property of AMETEK Process Instruments and may not be copied, reproduced, disseminated, or distributed without explicit written permission from AMETEK Process Instruments.

The statements, configurations, technical data, and recommendations in this document are believed to be accurate and reliable at the time of this publication, but AMETEK Process Instruments assumes no responsibility or liability for any errors or inaccuracies that may appear in this document.

AMETEK Process Instruments is not responsible for any infringement of patents or other rights of third parties that may result from the use of this document. The content of this document is furnished for informational purposes only, is subject to change without notice, and does not represent a commitment or guaranty by AMETEK Process Instruments.

AMETEK Process Instruments makes no warranty, express or implied, with respect to the content of this document. AMETEK Process Instruments shall not be liable for any loss or damage, including consequential or special damages, resulting from any use of this information, even if loss or damage is caused by AMETEK Process Instruments as a result of negligence or any other fault.

To obtain a PDF of this manual, visit our Products page at www.ametekpi.com.

Contents

SCOPE AND PURPOSE OF THIS DOCUMENT	1
Terms.....	1
Abbreviations.....	2
Product Support.....	2
Reference Standards.....	3
DEVICE DESCRIPTION	4
DESIGNING AN SIF USING A WDG-V COMBUSTION ANALYZER.....	5
Safety Function.....	5
Environmental Limits	5
Application Limits.....	6
Design Verification	6
SIL Capability.....	7
Systematic Integrity	7
Random Integrity.....	7
Failure Rates.....	7
Connection of the WDG-V Combustion Analyzer to the SIS Logic-Solver	7
General Requirements	8
INSTALLATION AND COMMISSIONING	9
Installation.....	9
Physical Location and Placement	9
OPERATIONS AND MAINTENANCE	10
Proof Test Without Automatic Testing.....	10
Repair and Replacement.....	11
Useful Life	11
Manufacture Notification.....	12
Aftermarket Excellence and Long-Term Commitment to Safety and Quality	12
Revision History.....	13
SECURITY	14
PRODUCT VERSIONS.....	15

This page intentionally left blank.

Scope and Purpose of This Document

This Safety Manual provides information necessary to design, install, verify and maintain a Safety Instrumented Function (SIF) utilizing the WDG-V Combustion Analyzer. It provides the necessary requirements for meeting the IEC 61508 or IEC 61511 functional safety standards.

Terms

Safety	Freedom from unacceptable risk of harm.
Functional Safety	The ability of a system to carry out the actions necessary to achieve or to maintain a defined safe state for the equipment/ machinery/plant/apparatus under control of the system.
Basic Safety	The equipment must be designed and manufactured such that it protects against risk of damage to persons by electrical shock and other hazards and against resulting fire and explosion. The protection must be effective under all conditions of the nominal operation and under single fault condition.
Safety Assessment	The investigation to arrive at a judgment – based on evidence – of the safety achieved by safety-related systems.
Fail Dangerous	Failure that does not respond to a demand from the process (i.e., being unable to go to the defined fail-safe state).
Fail Dangerous Undetected	Failure that is dangerous and that is not being diagnosed by automatic stroke testing.
Fail Dangerous Detected	Failure that is dangerous but is detected by automatic stroke testing.
Fail Annunciation Undetected	Failure that does not cause a false trip or prevent the safety function but does cause loss of an automatic diagnostic and is not detected by another diagnostic.
Fail Annunciation Detected	Failure that does not cause a false trip or prevent the safety function but does cause loss of an automatic diagnostic or false diagnostic indication.
Fail No Effect	Failure of a component that is part of the safety function but that has no effect on the safety function.
Low Demand Mode	Mode, where the frequency of demands for operation made on a safety-related system is no greater than twice the proof-test frequency.

Abbreviations

FMEDA	Failure Modes, Effects, and Diagnostic Analysis
HFT	Hardware Fault Tolerance
MOC	Management of Change: These are specific procedures often done when performing any work activities in compliance with government regulatory authorities.
PFDavg	Average Probability of Failure on Demand
SFF	Safe Failure Fraction: The fraction of the overall failure rate of a device that results in either a safe fault or a diagnosed unsafe fault.
SIF	Safety Instrumented Function: A set of equipment intended to reduce the risk due to a specific hazard (a safety loop).
SIL	Safety Integrity Level, discrete level (one out of a possible four) for specifying the safety integrity requirements of the safety functions to be allocated to the E/E/PE safety-related systems where Safety Integrity Level 4 has the highest level of safety integrity and Safety Integrity Level 1 has the lowest.
SIS	Safety Instrumented System: Implementation of one or more Safety Instrumented Functions. An SIS is composed of any combination of sensor(s), logic solver(s), and final element(s).

Product Support

For **Product Support** contact AMETEK with the following information:
AMETEK Process & Analytical Instruments Division
150 Freeport Road
Pittsburgh, PA, USA 15238
Phone: (412) 828-9040 Fax: (412) 826-0399

See also “Aftermarket Excellence and Long-Term Commitment to Safety and Quality” in this manual.

Related Literature

- **Product Documents:**
 - WDG-V Combustion Analyzer *User Manual* (9000-133-VE)
 - AME Q12-02-024 R001 V3 R2 WDG-V FMEDA Report
- **Guidelines/References:**
 - Safety Integrity Level Selection – Systematic Methods Including Layer of Protection Analysis, ISBN 1-55617-777-1, ISA
 - Control System Safety Evaluation and Reliability, 2nd Edition, ISBN 1-55617-638-8, ISA
 - Safety Instrumented Systems Verification, Practical Probabilistic Calculations, ISBN 1-55617-909-9, ISA

Reference Standards

Functional Safety

- IEC 61508: 2010 Functional safety of electrical/electronic/ programmable electronic safety-related systems
- ANSI/ISA 84.00.01-2004 (IEC 61511 Mod.) Functional Safety – Safety Instrumented Systems for the Process Industry Sector

Device Description

WDG-V analyzer is used for natural gas-fired power boilers and fired heaters or for those using gas during start-up and shutdown. The analyzer monitors both excess oxygen (O_2) and combustibles (specifically, CO and H_2) for maximum fuel efficiency. Please note that combustibles includes the products of incomplete combustion as a result of partial oxidation of fuel, such as CO and H_2 , and excludes hydrocarbon compounds, such as CH_4 . However, a separate methane detector can also be used to monitor the levels of unburned fuel, such methane and hydrocarbons, during purge and light-off cycles during start-up and shutdown. The unit is mounted directly to the process flange.

For a more detailed description of the functions of the WDG-V Combustion Analyzer, see WDG-V Combustion Analyzer *User Manual* (9000-133-VE).

This manual applies to all configurations of the WDG-V Series Combustion Analyzer, including the WDG-V, WDG-VC, WDG-VCM, and WDG-VM.

Designing an SIF Using a WDG-V Combustion Analyzer



The AMEVision is an optional tool used to configure the WDG-V series of oxygen analyzers and monitor their operation. To prevent unauthorized access to the WDG-V Sensor configuration, the user MUST activate the lockout mechanism (password protection) in the AMEVision unit. This process secures the analyzer by allowing only the authorized user to access the software. Refer to the AMEVision Display User Interface User Manual for details.

Safety Function

The WDG-V Combustion Analyzer measures the excess oxygen content of the process gas and ensures the 4–20 mA output represents the oxygen (O₂) content within the safety accuracy of the WDG-V Combustion Analyzer.

As a separate safety function, the WDG-V Combustion Analyzer can also measure the combustibles of the process gas using its RTD-type combustibles detector and ensures the 4–20 mA output represents the combustibles content within the safety accuracy of the WDG-V Combustion Analyzer. Please note that the combustibles detector monitors for the onset of incomplete combustion by alerting for products resulting from partial oxidation of fuel, such as CO and H₂, and excludes methane and other hydrocarbons.

These safety functions, for Oxygen and Combustibles (using the RTD-type detector), apply to all configurations of the WDG-V Series Combustion Analyzer:

- WDG-V (Oxygen Only)
- WDG-VC
- WDG-VCM
- WDG-VM

Environmental Limits

The designer of a SIF must check that the product is rated for use within the expected environmental limits. Refer to the AMETEK WDG-V Combustion Analyzer *User Manual* (9000-133-VE) for environmental limits.

Application Limits

The WDG-V is designed to be used in Category 3 hazardous locations where explosive gases may be present. Protection against explosion is provided by purge technique. It can be safely operated in a location in which:

- No gases are present with a higher probability of ignition than hydrogen (e.g., acetylene).
- The ambient temperature does not exceed 60 °C.
- Voltages are 104–127 VAC or 230 VAC, 700 VA. The unit has been tested to 230 VAC ±10 %.

The materials of construction of a WDG-V Combustion Analyzer are specified in the AMETEK WDG-V Combustion Analyzer *User Manual* (9000-133-VE). It is especially important that the designer check for material compatibility considering on-site chemical contaminants. If the WDG-V Combustion Analyzer is used outside of the application limits or with incompatible materials, the reliability data provided becomes invalid.

Design Verification

A detailed Failure Mode, Effects, and Diagnostics Analysis (FMEDA) report is available from AMETEK. This report details all failure rates and failure modes as well as the expected lifetime.

The achieved Safety Integrity Level (SIL) of an entire Safety Instrumented Function (SIF) design must be verified by the designer via a calculation of PFDavg considering architecture, proof-test interval, proof-test effectiveness, any automatic diagnostics, average repair time and the specific failure rates of all products included in the SIF. Each subsystem must be checked to assure compliance with minimum hardware fault tolerance (HFT) requirements.



The exida exSILentia® tool is recommended for this purpose as it contains accurate models for the components and their failure rates.

When using the WDG-V Combustion Analyzer in a redundant configuration, a common cause factor of at least 5 % should be included in safety integrity calculations.

The failure rate data listed in the FMEDA report is only valid for the useful lifetime of a WDG-V Combustion Analyzer. The failure rates will increase sometime after this period. Reliability calculations based on the data listed in the FMEDA report for mission times beyond the lifetime may yield results that are too optimistic (i.e., the calculated Safety Integrity Level will not be achieved).

SIL Capability

Systematic Integrity

The product has met manufacturer design process requirements of Safety Integrity Level (SIL) 2. These are intended to achieve sufficient integrity against systematic errors of design by the manufacturer. A Safety Instrumented Function (SIF) designed with this product must not be used at a SIL level higher than the statement without “prior use” justification by end user or diverse technology redundancy in the design.

Random Integrity

The product is a Type B Device. Therefore, based on the SFF between 60 % and 90 %, when it is used as the only component in sensor element, a design can meet SIL 2 @ HFT=0. When the final element assembly consists of many components (this device, actuator, solenoid, quick exhaust valve, etc.), the SIL must be verified for the entire assembly using failure rates from all components. This analysis must account for any hardware fault tolerance and architecture constraints.

Failure Rates

For detailed failure rate information, refer to the Failure Modes, Effects and Diagnostic Analysis Report for the WDG-V Combustion Analyzer.

Connection of the WDG-V Combustion Analyzer to the SIS Logic-Solver

The WDG-V Combustion Analyzer is connected to the safety rated logic solver which is actively performing the safety function. Diagnostic faults are communicated to the logic solver with the **Fault** relay. Since the WDG-V Combustion Analyzer has normal states during which the 4–20 mA signal is expected to be inaccurate (e.g., during oxygen sensor warm-up), the **DataValid** relay output communicates when the 4–20 mA signal is valid.

General Requirements

The excess oxygen detector's T90 response time (11 seconds) and RTD Combustibles detector T63 response time (25 seconds) shall be less than the process safety time. The WDG-V Combustion Analyzer periodically checks for internal faults every 90 seconds. The WDG-V Combustion Analyzer will set the **Fault** relay and the **DataValid** relay in less than one (1) second under specified conditions.

All SIS components, including the WDG-V Combustion Analyzer, must be operational before process start-up.

User shall verify that the WDG-V Combustion Analyzer is suitable for use in safety applications by ensuring that its nameplates confirm that the device is certified.

Personnel performing maintenance and testing on the WDG-V Combustion Analyzer shall be competent to do so. See the AMETEK WDG-V Combustion Analyzer *User Manual* (9000-133-VE) for more information on competencies required (see "Important Notice to Users" section).

Results from the proof tests shall be recorded and reviewed periodically.

The useful life of the WDG-V Combustion Analyzer is discussed in the Failure Modes, Effects, and Diagnostic Analysis (FMEDA) Report.

Installation and Commissioning

Installation

The WDG-V Combustion Analyzer must be installed per standard practices outlined in the WDG-V Combustion Analyzer *User Manual* (9000-133-VE).

The environment must be checked to verify that environmental conditions do not exceed the ratings.

The WDG-V Combustion Analyzer must be accessible for physical inspection.

Physical Location and Placement

Installation of the WDG-V Combustion Analyzer must provide room to allow for manual proof testing.

The WDG-V Combustion Analyzer shall be mounted in a low vibration environment. If excessive vibration can be expected take special precautions to ensure the integrity of all connectors, or the vibration should be reduced using appropriate damping mounts.

Operations and Maintenance

Proof Test Without Automatic Testing

The objective of proof testing is to detect failures within WDG-V Combustion Analyzer that are not detected by any automatic diagnostics of the system. The primary concern is undetected failures that prevent the safety instrumented function from performing its intended function.

The frequency of proof testing, or the proof test interval, is to be determined in reliability calculations for the safety instrumented functions for which a WDG-V Combustion Analyzer is applied. The proof tests must be performed more frequently than, or as frequently as specified in, the calculation in order to maintain the required safety integrity of the safety instrumented function.

The following proof test is recommended. The results of the proof test should be recorded and any failures that are detected and that compromise functional safety should be reported to AMETEK.

RECOMMENDED PROOF TEST

1. Bypass the safety function and take appropriate action to avoid a false trip.
2. Use AMEVision Display User Interface or the WDG-V Configurator Software to retrieve any diagnostics and take appropriate action.
3. Using the user interface, command to the transmitter to go to the high alarm current output and verify that the analog current reaches that value.¹ Conduct this test for both the excess oxygen and the combustibles outputs and analog currents.
4. Using the user interface, command to the transmitter to go to the low alarm current output and verify that the analog current reaches that value.² Conduct this test for both the excess oxygen and the combustibles outputs and analog currents.
5. Inspect the analyzer for any leaks, visible damage, or contamination.
6. Perform a full calibration of the analyzer over the full working range.
7. Inject test gas at 50 % of the calibrated range to verify accuracy within the safety accuracy range.
8. Remove the bypass and otherwise restore normal operation.

¹ This tests for compliance voltage problems such as a low loop power supply voltage or increased wiring resistance. This also tests for other possible failures.

² This tests for possible quiescent current related failures.

This test will detect >76 % of possible DU failures for the excess oxygen measurement and >59 % of possible DU failures for the RTD combustibles measurement in the WDG-V Combustion Analyzer.

The person(s) performing the proof test of a WDG-V Combustion Analyzer should be trained in SIS operations, including bypass procedures, WDG-V Combustion Analyzer maintenance and company Management of Change procedures. No special tools are required.

Repair and Replacement

Repair procedures in the WDG-V Combustion Analyzer *User Manual* must be followed.

Useful Life

The useful life is up to 5 years for the Excess Oxygen sensor for clean gas-fired applications. Please note that dirtier and severe service applications can reduce the useful life of the sensor to 1–3 years.

The useful life of the RTD Combustibles Sensor is up to 3 years for clean gas-fired applications. Please note that dirtier and severe service applications can reduce the useful life of the sensor to 1–2 years.

The useful life of the WDG-V Combustion Analyzer is 50 years. This useful life begins after the analyzer is installed and operating on process. Please note that the Excess Oxygen and Combustibles sensors limit the useful life of the analyzer, and the sensors must be replaced at their respective end of life. It is the responsibility of the end user to maintain and operate the WDG-V Combustion Analyzer per the analyzer *User Manual* and this *Safety Manual*. Furthermore, regular inspection should show that all components are clean and free from damage.

Manufacture Notification

Any failures that are detected and that compromise functional safety should be reported to AMETEK. See “Product Support,” earlier in this manual, and “Aftermarket Excellence and Long-Term Commitment to Safety and Quality,” below, for information on how to contact AMETEK.

Aftermarket Excellence and Long-Term Commitment to Safety and Quality

Our goal is to make your experience with our products exceptional. We stand behind our analyzers with a broad service offering that provides a sense of security long after the initial purchase has been made. We commit to fulfilling your service needs with speed, quality, and professional consideration.

From delivering on-site technical support to in-house repair at one of our service centers, our experienced technicians are knowledgeable and helpful. We also offer remote virtual support and a variety of training options.

Scan the QR code or click the link below to request expert Aftermarket support for parts, repairs, service, training, and more:



www.ametekpi.com/customersupport/aftermarket

Revision History

Revision	Date	Change	Author
1	3/21/18	Initial Release	C Kolesar
A	7/27/18		C Kolesar
B	7/31/18	Added Security	C Kolesar
C	8/3/18	Change detect % DU failures	C Kolesar
D	8/6/18	Product Versions	C Kolesar
E	2/17/23	Added RTD Combustibles Detector	C Kolesar

Security

Configuration changes on the WDG-V are made via the MODBUS RTU and HART interfaces. These interfaces are intended for use only by qualified and authorized personnel. The user must ensure that any device used to communicate with the analyzer via MODBUS or HART is protected from cyber security threats. To this end, any device connected to the WDG-V Combustion Analyzer must meet the following requirements and user conduct for safe and secure operation:

- The MODBUS RTU and/or HART interface must be secure from physical tampering.
- The configuration device must prevent access via a secure password.
- Passwords must be securely managed to keep them private to only authorized personnel.
- To prevent session stealing, once logged in and after making changes, the user must immediately log out of the configuration device. Never leave the device without logging out.
- The configuration device must not be accessible via a TCP/IP network.
- The WDG-V MODBUS and HART register maps must only be disseminated to qualified and authorized personnel.
- Personnel must be properly trained to prevent authorized, improper configuration of the analyzer. Proof tests, as defined in the safety manual, must be performed after any configuration changes via MODBUS or HART.
- Configuration changes must only be performed offline. The updated configuration must be validated prior to returning the WDG-V to online operation.

Product Versions

The following versions apply to the WDG-V SIL analyzer:

- Hardware Assembly (9000-147-VE): REV V
- Electronics Assembly (8000-120-SE): REV N
- Electronics Assembly (8000-119-SE): REV E
- Software Revision: V1.15

AMETEK Process Instruments delivers worldwide sales and service support through a network of direct and factory-trained global distribution channels.

AMETEK Service Assistance Program plans offer coverage up to 24 hours a day, 365 days of the year.

As worldwide experts in the manufacture of process analyzers and instrumentation, we have supplied solutions to industry since 1962, providing the widest range of analysis technology available.

Through process application consulting, we create custom-designed solutions that meet the needs of your specific application or process.

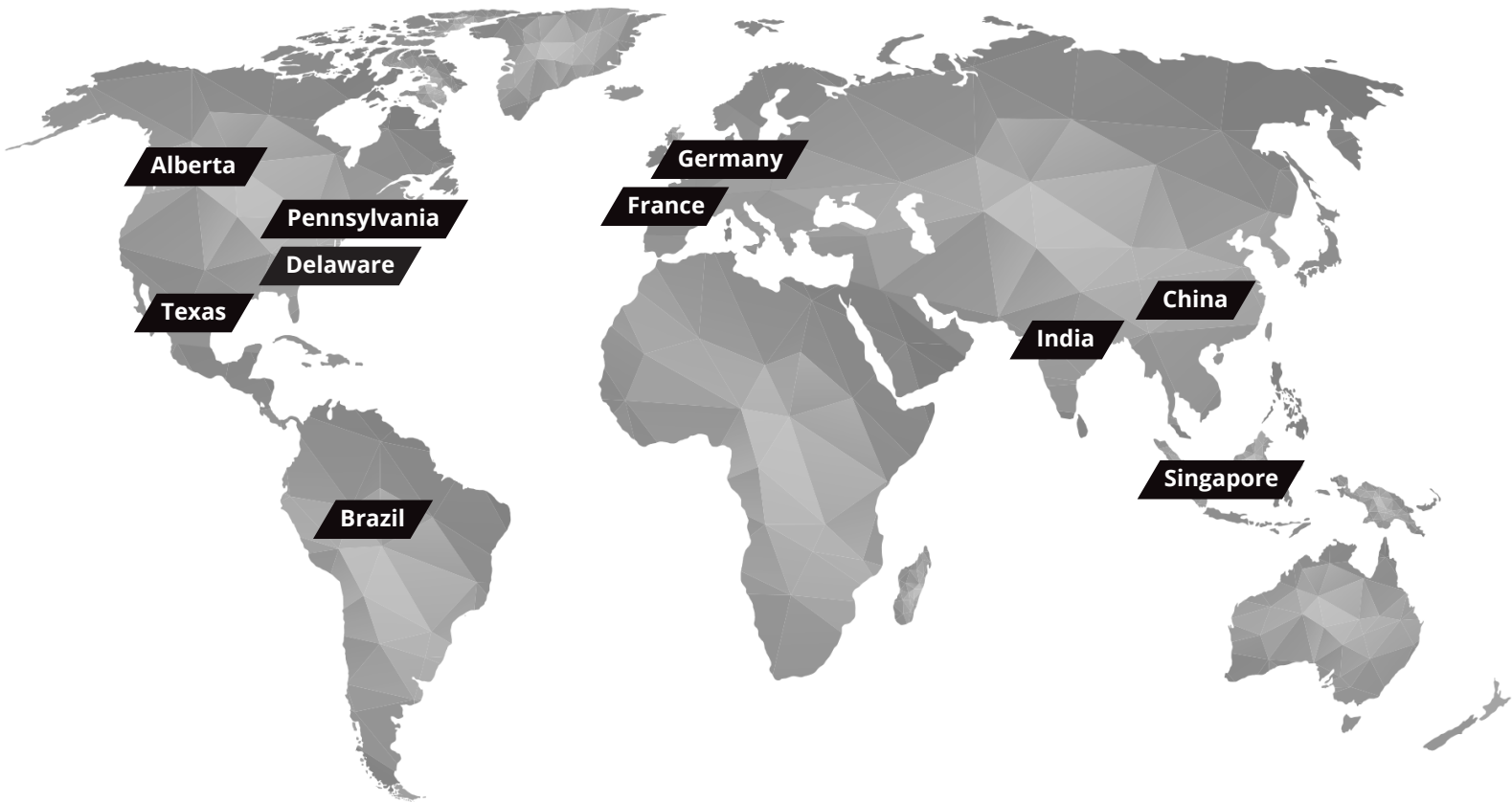

SALES, SERVICE & MANUFACTURING

USA - Pennsylvania

150 Freeport Road
Pittsburgh PA 15238
Tel: +1 412 828 9040
Fax: +1 412 826 0399

USA - Delaware

455 Corporate Blvd.
Newark DE 19702
Tel: +1 302 456 4400
Fax: +1 302 456 4444

Canada - Alberta

2876 Sunridge Way NE
Calgary AB T1Y 7H9
Tel: +1 403 235 8400
Fax: +1 403 248 3550

WORLDWIDE SALES AND SERVICE LOCATIONS

USA

Tel: +1 713 466 4900
Fax: +1 713 849 1924

Brazil

Tel: +55 19 2107 4100

France

Tel: +33 1 30 68 89 20
Fax: +33 1 30 68 89 99

Germany

Tel: +49 2159 9136 0
Fax: +49 2159 9136 39

India

Tel: +91 80 6782 3200
Fax: +91 80 6780 3232

Singapore

Tel: +65 6484 2388
Fax: +65 6481 6588

China

Beijing
Tel: +86 10 8526 2111
Fax: +86 10 8526 2141
Chengdu
Tel: +86 28 8675 8111
Fax: +86 28 8675 8141
Shanghai
Tel: +86 21 5868 5111
Fax: +86 21 5866 0969



© 2023, by AMETEK, Inc. All rights reserved. Printed in the U.S.A.
One of a family of innovative process analyzer solutions from AMETEK Process Instruments.
Specifications subject to change without notice.

